



INSTRUMENTATION AND EVALUATION OF DISTRICT 10 CALTRANS AUTOMATED WARNING SYSTEM (CAWS)

Technical and Operational Assessment

Prepared for the California Dept. of Transportation and California Office of Traffic Safety
by Loragen Corporation, San Luis Obispo, California

Project Manager: Andrew Lee, Caltrans Division of Innovation and Research

Principal Investigator: Art MacCarley

OTS Grant No. RS0034, Caltrans Contract No. 51A0050

Document No. L-D10-FR-03

September 25, 2005

Table of Contents

Technical and Operational Assessment	1
3.1 Evaluation Objectives	1
3.2 System Technical Inspection	2
3.2.1 Central Control (TMC) Components	2
3.2.2 Field Elements	8
3.2.3 Traffic Monitoring Stations	9
3.2.4 Changeable Message Signs (CMS)	12
3.2.5 Qualimetrics Remote Weather Monitoring Stations	13
3.3 Examination of the CAWS Response to Traffic and Weather Events	17
3.3.1 Activation Case Histories	17
3.3.2 Speed-Related System Response	19
3.3.2.1 November 14, 2003	20
3.3.2.2 July 6, 1997	27
3.3.2.3 TMS/Speed Station Communications Problems, Various Dates	34
3.3.3 Fog-Related System Response	35
3.3.3.1 December 2, 2003	37
3.3.3.2 January 12, 2004	41
3.3.3.3 January 1–13, 2004	44
3.3.3.4 February 2 – March 19, 2005	45
3.3.3.5 January 2, 2004	45
3.3.3.6 January 19, 2004 and January 30, 2004	47
3.3.4 Weather System Communications-related Problems, Various Dates	48
3.3.5 Manual Warning Events – Problems with Automatic Override	52
3.3.5.1 August 9, 2004	53
3.3.5.2 October 10, 2004	54
3.3.5.3 December 12, 2004	56
3.4 General Control and Data Logging Issues	57
3.4.1 Loop Detector Problems Causing CMS Activations	57
3.4.1.1 August 29, 2004	57
3.4.1.2 October 24, 2004	58
3.4.1.3 February 22, 2005	59
3.4.2 Conflicts Between Speed Activation and Weather Activation	61
3.4.2.1 February 25, 2004	61
3.4.2.2 January 21, 2004	62
3.4.2.3 November 17, 2004	66
3.5 Analysis of CAWS Software	69
3.5.1 Traffic Monitoring System (TMS)	70

3.5.1.1	Program Overview	70
3.5.1.2	Warning Condition Persistence for CMS Activations	73
3.5.1.3	Logging Interval	74
3.5.1.4	Data Communication Error Assignment	75
3.5.1.5	System hang-up due to communications errors	75
3.5.1.6	Field Master Name Hardcoding	78
3.5.1.7	Speed Data Qualification	79
3.5.1.8	TMS to Signview Communications	81
3.5.1.9	Inconsistent Use of Global Program Constants	82
3.5.1.10	Contradictory CMS Bulb Map Indexing	82
3.5.1.11	Improper Data Conversions	83
3.5.1.12	Speed Validation Criteria	84
3.5.1.13	Lack of Pre-Incident Data Logging	84
3.5.2	Signview/CAWS	84
3.5.2.1	Response to visibility alarms – failure to display message for level 3	84
3.5.2.2	Inability to alert for fog without RH sensor, or to detect failure of RH sensor	87
3.5.2.3	Pre-emption of manually placed messages by automatically-generated messages	88
3.5.2.4	Failure to log blank messages	88
3.5.2.5	Possible reversal of Signview activation priorities due to polling order	88
3.5.2.6	Progressive sequencing of fog warning messages	89
3.5.2.7	Need for a “reduced function mode” and a graceful degradation plan.	89
3.5.3	Qualimetrics Caltrans Meteorological Monitoring System (QCMS) Software	90
3.5.3.1	General mode operation and interface with Signview	90
3.5.3.2	Persistence of QCMS alarm codes after communications failures.	91
3.5.3.3	Erroneous alarm levels during boot-up	91
3.5.4	General Issues, All Systems	92
3.5.4.1	System lag due to multiple excessive polling intervals	92
3.5.4.2	Need for sensor validation and graceful degradation	96
3.5.4.3	Lack of documentation and operators manual	96
3.5.4.4	Time synchronization between the three CAWS computers	96
3.5.4.5	CMS messages remain in event of system failure	97
3.5.4.6	Binary (non-text) log files	97
3.6	Specific Recommendations for Corrections to Software or Control Strategy	98
3.6.1	Critical Recommendations	98
3.6.2	Non-critical but strongly recommended corrections	102
3.6.3	Other Advised Improvements	104
3.6.4	Corrective Actions Completed to Date	106
3.7	Technical and Operational Assessment General Conclusions	107
3.8	Appendix	110

3.8.1	TMS Control Mapping	110
3.8.2	Data Conversion Utilities	115
3.8.2.1	D-10 Analyzer	115
3.8.2.2	Speed log file conversion	116
3.8.2.3	Weather log file conversion	117
3.8.2.4	Signview Logs	119
3.8.3	Index to CD Containing Supporting Data and Utilities	120

Tables

Table 3.3.1.1. Activations of CAWS during study period.	18
Table 3.3.2.1. Raw Speed Data.	26
Table 3.3.3.1. Weather Log (1-8-04).	44
Table 3.3.3.2. Weather Log (1-11-04).	45
Table 3.3.3.3. CAWS-evaluation CMS 1 Messages.	46
Table 3.3.3.4. Weather Log (1-2-04).	46
Table 3.3.3.5. Weather Log (1-19-04).	47
Table 3.3.3.6. Weather Log (1-19-04).	47
Table 3.3.3.7. Weather Log (1-30-04).	48
Table 3.3.3.8. Signview Log.	48
Table 3.3.4.1. QCMS Weather Log, 8-9-04.	49
Table 3.3.4.2. Signview Log.	49
Table 3.3.5.1. Amber Alert messages placed on CMS 1, Aug. 2002 – March 2005.	53
Table 3.3.5.2. Signview Message Log.	54
Table 3.3.5.3. CAWS-evaluation database entries.	54
Table 3.3.5.4. Weather Log (8-9-04)	54
Table 3.3.5.5. Signview Log.	55
Table 3.3.5.6. Weather Log for Site 5 (10-19-04).	55
Table 3.3.5.7. Signview log entries.	56
Table 3.3.5.8. Speed log for stations capable of activating CMS 2.	56
Table 3.3.5.9. Speed log related to CMS 5.	57
Table 3.4.1.1. Speed Log (8-29-04).	58
Table 3.4.1.2. Hourly samples from Signview Log.	58
Table 3.4.1.3. Signview log entries.	59
Table 3.4.1.4. Speed log (3-19-05).	59
Table 3.4.1.5. TMS Speed Log (3-31-05).	60
Table 3.4.2.1. Signview Log.	61
Table 3.4.2.2. Weather Log (2-25-04).	61
Table 3.4.2.3. Speed Log (2-25-04).	62
Table 3.4.2.4. Signview Log entries for CMS 5, 4:56 am – 8:55 am.	63
Table 3.4.2.5. Speed log for stations which could activate CMS 5 (1-21-04).	63
Table 3.4.2.6. Signview Log for CMS 9, 4:56 am – 8:55 am.	64
Table 3.4.2.7. Speed log for stations which could activate CMS 9 (1-21-04).	65
Table 3.4.2.8. Weather Log for CMS 5 and CMS 9 (1-21-04).	66
Table 3.4.2.9. Signview Log.	67
Table 3.4.2.10. Weather Log (11-17-04).	67
Table 3.4.2.11. Speed Log (11-17-04).	68
Table 3.5.1.1. Speed Condition Numbers and Associated Conditions.	71

Table 3.5.1.2. Speed Flag Sum and Inferred Traffic Condition.	71
Table 3.5.1.3: Example Polling of Speed Data	74
Table 3.5.1.4. Communications Sequence Causing Potentially Incorrect Traffic Warnings.	75
Table 3.5.1.5. Selected Constants in TMS Software.	82
Table 3.5.4.1. Response delays measured for CMS 1, 2004-05. Delay is in seconds.	92
Table 3.5.4.2. CAWS activation delay for fog messages at CMS 1.	96
Table 3.8.1.1. TMS Original Control Mapping Table.	113
Table 3.8.1.2. TMS Current Control Mapping Table.	114

Table of Figures

Figure 3.2.1.1. CAWS computers. From left to right: Signview/CAWS, Qualimetrics-Caltrans Meteorological System (QCMS), Traffic Monitoring System (TMS).	2
Figure 3.2.1.2. CAWS Control Priority Tree.	4
Figure 3.2.1.3. Time correction process diagram.	6
Figure 3.2.2.1. CAWS elements deployed on I-5 and SR-120. From Caltrans as-built drawings for CAWS project.	8
Figure 3.2.3.1. Inside of Type 334c control cabinet containing CAWS traffic monitoring equipment.	9
Figure 3.2.3.2. Duplex inductive loops installed in each lane for speed measurement at each traffic monitoring station.	10
Figure 3.2.4.1. CMS 1, located near County Hospital Road (day on left, ADVISE 45 MPH Message in middle, dusk on right).	12
Figure 3.2.4.2. CMS 1 panel replacement, recorded by our CMS verification camera on Nov. 17, 2003.	13
Figure 3.2.5.1. Weather Station 4 on Interstate 5.	14
Figure 3.2.5.2. Visibility distance reference placards installed south of WS 4 by Caltrans District 10 personnel for manual verification of local visibility.	15
Figure 3.2.5.3. Qualimetrics Model Z004510 forward scatter visibility sensor (center) and Model 5140 temperature/humidity probe (left), installed at each remote weather station in the CAWS.	16
Figure 3.2.5.4. Day/night sensor blocked by spider egg sac.	17
Figure 3.3.2.1. Accident Locations (2004-11-14).	21
Figure 3.3.2.2. Speed Site 9A.	22
Figure 3.3.2.3. Speed Site 9B.	22
Figure 3.3.2.4. Graphical Signview Log (2003-11-14).	24
Figure 3.3.2.5. Graphical Signview Log File (1997-07-06).	28
Figure 3.3.2.6. SR-120 Speed Site – CMS Mapping.	30
Figure 3.3.2.7. Speed Station 8E Speed Data.	31
Figure 3.3.2.8. Speed Station 9E Data Plot.	33
Figure 3.3.3.1. Graphical Signview Log File (2003-12-02).	38
Figure 3.3.3.2. Speed Site 9D Speed Data.	40
Figure 3.3.3.3. Speed Site 9E Speed Data.	40
Figure 3.3.3.4. CHP Accident Site Sketch.	42
Figure 3.3.3.5. Accident Location (2004-01-12).	43
Figure 3.3.4.1. D10 Analyzer Screenshot	49
Figure 3.3.4.2. D10 Analyzer Screenshot, showing graphical depiction of fog over the course of an activation event, 11-07-04.	50
Figure 3.3.4.3. Visibility at WS 1, 9-day profile starting 1-26-05, from D10 Analyzer.	51
Figure 3.3.4.4. D10 Analyzer Screenshot, 2-17-05 through 2-24-05.	51
Figure 3.3.4.5. D10 Analyzer Screenshot.	52

Figure 3.5.1.1. WB SR-120 Merge to SB I-5 at Mossdale Y.	80
Figure 3.5.1.2. I-5 to I-205 Traffic Pattern.	81
Figure 3.5.2.1. Decoding of alarm levels from QCMS master computer data byte. From QCMS User's Manual.	86
Figure 3.5.2.2. Fog level alarm byte bit definitions.	87
Figure 3.8.1.1. 'Mossdale Y' Speed Monitoring Station Locations.	110
Figure 3.8.1.2. TMS Original Control Mapping, CMS <-> Speed Monitoring Stations.	111
Figure 3.8.1.3. TMS Current Control Mapping, CMS <-> Speed Monitoring Stations.	112

Technical and Operational Assessment

3.1 Evaluation Objectives

The original evaluation objectives specified separate technical and operational evaluation tasks. The results of these assessments have been merged into this common document due to the synergy and potential redundancy between these topics.

The objective of the technical assessment was to “verify and document the systems under test”, and “assess conformity to nominal specifications”. These tasks were completed in the course of the operational assessment, as we gained experience with and learned more about the internal workings of the various components of the CAWS. Components included in this assessment were the Qualimetrics-Caltrans Meteorological System (QCMS) weather station components, the field traffic monitoring components, and the Signview, TMS and QCMS computers and their software located in the District 10 TMC.

The objective of the operational assessment was to examine the implementation of the system, and determine if the system performed according to the original design expectations and operators’ assumptions. (Not the same as the effect on driver behavior or the success in terms of collision rate reduction, which are the subjects of subsequent volumes of this report.) In this document we examine the implementation of each of the key elements of the CAWS. We then observe the response of the automated system to a range of conditions that triggered, or should have triggered, a warning message on one or more of the nine changeable message signs. The responses either confirmed the basic function of the system as designed, or revealed unexpected behaviors that required deeper investigation. When necessary to explain these unexpected behaviors, we identified the actual control strategy by detailed examination of the CAWS/Signview or TMS computer logs and source code, in addition to data available from our evaluation data acquisition network.

We examine the operational characteristics of the CAWS via a number of case histories indicative of the range of possible responses of the system to speed-related and visibility-related trigger events. The cases described below are samples of automated actuations of the CAWS, selected because they provided the greatest insight into the system control strategy and actual system response. All data were obtained from the Signview, TMS, or QCMS log files, or when applicable, the CAWS Evaluation System database.

3.2 System Technical Inspection

3.2.1 Central Control (TMC) Components

The Caltrans Automated Warning System (CAWS) is controlled by a network of three computers located in the District 10 Traffic Management Center. Central to this cluster is the **Signview/CAWS** computer which controls the activation of all warning messages displayed on nine Changeable Message Signs (CMS) via a hierarchical control strategy based upon field data including traffic speeds, visibility, and high winds. It receives data inputs from the **Traffic Monitoring System (TMS)** computer which is connected to 36 speed monitoring sites, and alarm triggers from the **Qualimetrics-Caltrans Meteorological System (QCMS or weather)** computer which is connected to nine remote weather stations. Physically, the three computers communicate over RS-232 serial connections. Data flow from the TMS and QCMS computers to the Signview/CAWS computer is unidirectional. These are shown in Figure 3.2.1.1.



Figure 3.2.1.1. CAWS computers. From left to right: Signview/CAWS, Qualimetrics-Caltrans Meteorological System (QCMS), Traffic Monitoring System (TMS).

The Signview/CAWS and TMS programs were developed by a team of programmers in Caltrans Traffic Operations: Joel Retanan, Tadeo Lau, and Celso Izcuera, under the supervision of Floyd Workmon. The Signview/CAWS program, which performs the actual CMS activation functions, was a modification of the previous Signview program in widespread by Caltrans for manual placement of messages CMSs. The modifications added the ability to automatically display messages from an inventory of “canned”

messages, based upon a simple priority and decision structure discussed in various subsections below. The TMS program was created originally for the CAWS project, although it is currently in use in several other Caltrans Traffic Management Centers (TMCs) for displaying and logging speed data from field monitoring sites. It was designed to provide a means for generating speed-based triggers for the Signview program, and also a user interface for monitoring up to 36 speed detection sites. Both Signview/CAWS and TMS are DOS applications, based on DOS 6.0. They rely on direct access to the serial ports, and therefore cannot easily be ported to MS/Windows environment. The QCMS program is a proprietary Windows 95 program provided by Qualimetrics (now All-Weather Systems of Sacramento) as one of the components of the Caltrans Meteorological System which they were contracted to provide. The program provides a user interface and logging capability for monitoring all instruments at each of the nine remote weather stations, but also provides user-settable alarm threshold triggers which the Signview/CAWS program uses for CMS activations decisions.

All sensor, processing and display hardware that constitute the CAWs were found to be fully functional, and remarkably reliable. For example, the consumer-type DOS PC's that implement the TMS and Signview programs were still operational with original motherboards and hard disks after seven years of continuous operation. The graphical user interfaces provided by the meteorological system and the traffic monitoring system appeared to be intuitive and well-designed. The fact that one system ran under Windows 95 and the other two under DOS did not appear to be a problem with respect to present needs, but could potentially limit future enhancements.

Based upon field inspections we concluded that the meteorological system was engineered and installed to very high quality standards, and appeared to be fully functional at all sites most of the time. The visibility and RH sensors, both critical to fog detection, proved to be high-maintenance components than expected, as will be discussed later.

We observed that traffic counts reported by the Type 170 controller at the inspected site seemed to run consistently higher than expected, suggesting that the actual loop separation had not yet been calibrated for the speed detection algorithm.

The unique CAWS architecture endows it with potentially powerful control capabilities. These capabilities are not fully utilized in the existing system. Each of the nine QCMS automated weather stations provides real time data on atmospheric visibility, temperature, relative humidity (RH), barometric pressure, rainfall, wind speed, wind direction and illumination level. From these are derived additional measurements such as fog-limited-visibility (a function of visibility, RH and illumination level), dew point (a function of temperature and RH), and ice point (a function of temperature, RH, and barometric pressure). The QCMS computer generates programmable alarm signals for all these sensors, and derived measurements, which it transmits to the Signview/CAWS computer. The Signview/CAWS computer utilizes only the alarm thresholds generated for fog and wind speed. The QCMS provides three levels for

each; the CAWS uses only two levels for fog warnings which generate two possible fog messages, and one level for wind speed which generates one high wind warning message. One weather station is associated uniquely with one CMS; no advantage is taken of the central control architecture to provide data validity checking or logical/progressive sequencing of the CMS messages viewed by drivers.

The TMS computer generates activation decisions based upon combinations of speed data from the 36 speed monitoring sites. Signview/CAWS responds to these triggers by placing either a “SLOW TRAFFIC AHEAD” or “STOPPED TRAFFIC AHEAD” message on the CMS immediately prior to the speed monitoring site that detected a slowdown or stopped traffic. A “HIGHWAY ADVISORY AHEAD” message is displayed on the CMS prior to the CMS displaying the warning message, which provides advance warning to drivers to watch for a subsequent speed warning message. No equivalent advanced warning is provided for fog warnings. Traffic detection decisions are based solely on mean speed measurements, although the lane volume is checked as a way to verify that the speed measurement was valid. A traffic volume of zero indicates that the speed measurement is not current for the present polling period, or that a detection error had erroneously generated the speed measurement. Although the speed monitoring sites are capable of measuring traffic volume or gap over the polling period, these or other metrics which utilize vehicle separation as well as speed are not used to trigger warning messages. The speed detection logic considers individual lane speeds using an algorithm which will be described below. Speed alarms are generated by the TMS computer and communicated to the Signview/CAWS computer.

The Signview/CAWS program (usually) implemented the warning priority structure depicted in Figure 3.2.1.2 below, with highest priority assigned to speed-related triggers, followed by fog, and at lowest priority, manually inserted messages entered on the computer console. Each higher level supercedes the level(s) beneath it. However, we identified situations in which this prioritization could be reversed for periods up to one complete polling period, in rare cases in which polling synchronization was lost. These will be discussed later.

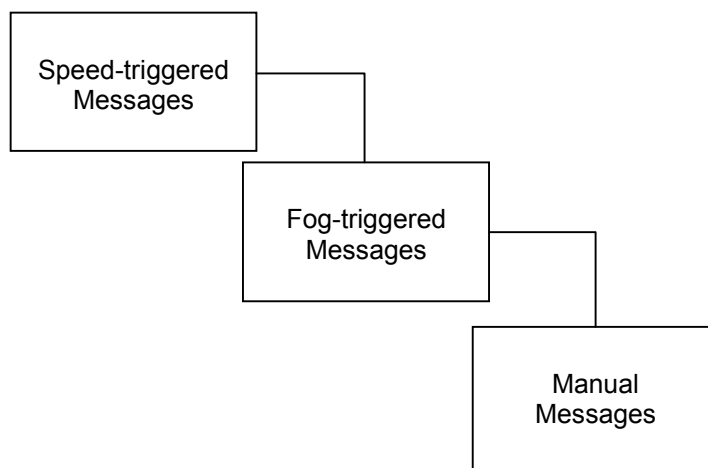

Figure 3.2.1.2. CAWS Control Priority Tree.

The priority is implemented such that any speed-triggered message overrides a fog-triggered message, and both will override a manually placed message such as an Amber Alert message. For example, a "SLOW TRAFFIC AHEAD" message will override a "FOGGY CONDITION AHEAD, ADVISE 30 MPH" message. If a fog trigger condition is still present at the time that a speed message is discontinued, the fog message will be renewed the following polling period. If a manual message is overridden at any time by an automated (speed or fog) message, it will not be renewed at the completion of the speed or fog messages unless it manually re-entered. Note that since Amber Alert messages are generally entered only once from the Signview computer console, if such a message is superceded even once by a traffic, fog or high wind message, it will not be reactivated once the superceding message is extinguished. This priority also prevents the manual override of automatically generated messages for more than the time remaining in a three-minute polling period, after which the manual message will be replaced by the automatically generated one.

As mentioned above, the normal polling cycle for CMS message updates is nominally three minutes. (Manually-placed messages can be activated asynchronously.) But a separate 15-minute polling cycle is used by the QCMS and a 50-second polling cycle (15 minute logging cycle) is used by the TMS computers to gather data from the weather and speed sites respectively. Since the data collection and CMS update cycles operate independently, a delay of between three (minimum) and eight (maximum) minutes will elapse between the moment of detection of any detection event and the corresponding CMS message response. Using precise time measurements from our evaluation test sites for reference, we have observed an average CAWS reaction delay of 7.9 minutes. The ramifications of this delay will be illustrated clearly in the Driver Response Analysis of this final report. Log file entries are generated on each of the CAWS computers once every polling cycle, although these are not always recorded (to be discussed below).

Log time entries generated by each of the three CAWS computers are based on the DOS (Signview or TMS) or Windows (QCMS) system clocks in the computers. DOS clocks are particularly prone to drift since DOS only checks the motherboard real time clock at boot time, and thereafter maintains the system time relative to the processor clock rate, which is not a stable reference. Since the clocks of the TMS computer, the QCMS computer and the Signview computer run independently, they have been found to drift with respect to each other by as much as 30 minutes per month. District 10 personnel periodically manually reset the clocks on the Signview and TMS computers, usually about once a month.

The time misalignment was reflected in the log files generated independently by each computer. To compensate, time offsets were made to the times in the log files of each system, utilizing common events revealed in the records of each proximate to the event of interest. The manual time correction process involves reference, via the log files of each of the CAWS computers, to the CAWS Evaluation database which maintained absolute time synchronized via the Internet with the NIST Atomic Clock in Colorado.

The CAWS evaluation system reads, logs, and timestamps messages sent to CMS 1 (County Hospital). An overview of this operation is shown in Figure 3.2.1.3. This provides a link between the Signview log file times and absolute time as maintained by the CAWS Evaluation System. We identify the closest event that causes message activation at CMS 1. We then adjust the TMS computer's data based on the corrected Signview log file times. This is done by searching for an identical event in the TMS computer's data that caused a Signview message activation.

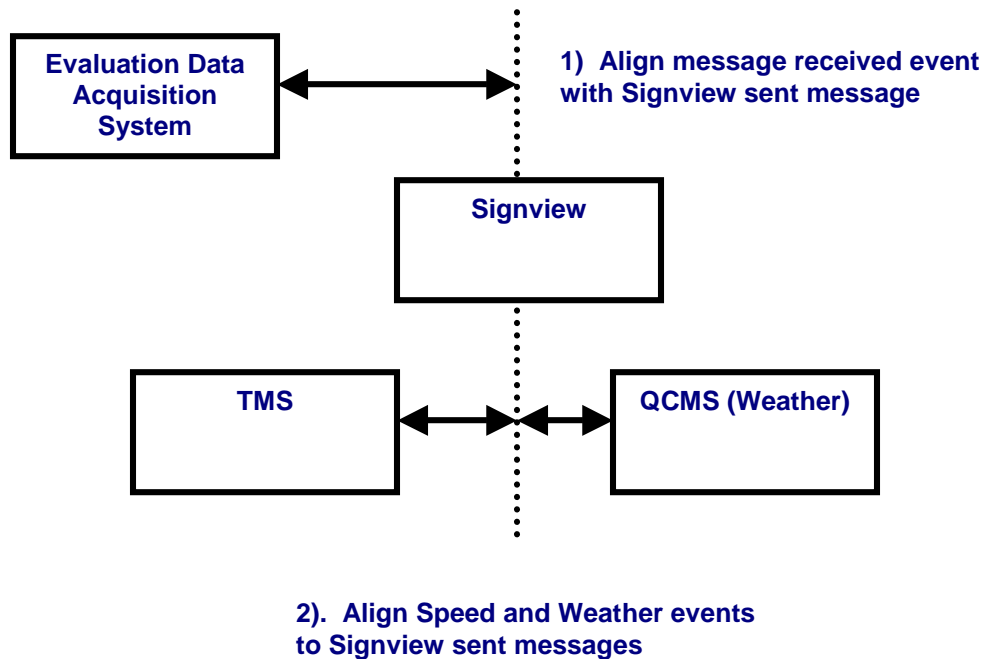

Figure 3.2.1.3. Time correction process diagram.

For convenience in interpreting the log files, we used the Signview computer time and its log files as the common time reference for all events described below, except if otherwise stated. Not that this time is not accurate in an absolute sense.

The CAWS time misalignment problem was eventually rectified in December 2004 when, with permission of district personnel, we installed precision real-time clock cards (accurate to 0.1 second/month) in the TMS and Signview computers. This was the only possible solution these computers do not have access to the Internet which could provide network time-synchronization.

The originally implemented version of the Signview/CAWS was designated as Signview 3.0. It was updated in September 1997 to Signview 3.11, with changes including the correction of the mapping of speed monitoring stations to CMSs. The current version of the Signview/CAWS program is 3.12, which differs from Signview/CAWS 3.11 by the addition of one line to enable the logging of blanking message,

required for evaluation purposes so that the log would show the time that a given message was turned off. This small modification was requested by the evaluators and was implemented in September 6 2004 by District staff with the support of Mr. Retanan.

Signview/CAWS (or just Signview for the remainder of this document), was a modification of the Signview program already in widespread use by Caltrans for manual activation of CMSs. Signview/CAWS was a radically modified version of Signview which added fully automatic message generation and CMS activation based on inputs from two other computer systems (TMS and QCMS).

The Signview program receives data from the QCMS and the TMS computers via serial links. When Signview receives updated information, it will generate and send new corresponding CMS messages in the next polling cycle. The protocol may be summarized:

1. Signview initializes an empty speed alarm sum map to all normal conditions (alarm sum 0) for all speed monitoring stations.
2. Signview polls the TMS computer which only sends the ID and speed alarm flag sum for affected sites (speed alarm sum will be described in later subsections).
3. Signview updates the speed alarm sum map accordingly.
4. The control algorithm and activation priorities described in subsection 3.5.1 are performed.
5. The 'Message Issuing function' is called in Signview, which handles the propagation of CMS graphical messages.

The Signview software does not log information about which speed stations caused a warning message activation. In some instances, six different speed sites have the potential to activate a single CMS message.

Beyond the basic operational characteristics and issues described above, which were known and understood by the system operators, the more subtle (but critical) details of the control strategy were not known, since no formal documentation had been created when the system was developed and deployed. Fortunately, one of the three original programmers of the Signview/CAWS or TMS software could be consulted, but due to the age of the program, most details were beyond recall. The process of discovery required that we observe the actual operation of the system via the log files generated by each of the three CAWS computers. And for those events that affected CMS 1, we could investigate much more deeply since it was monitored by the CAWS evaluation system.

3.2.2 Field Elements

A map showing the deployment of CAWS elements on southbound I-5 and westbound SR-120 is shown in Figure 3.2.2.1.



Figure 3.2.2.1. CAWS elements deployed on I-5 and SR-120. From Caltrans as-built drawings for CAWS project.

3.2.3 Traffic Monitoring Stations

As previously discussed, the CAWS TMS (Traffic Monitoring System) computer communicates with 36 traffic monitoring stations (field sites), each with a Type 334c cabinet containing a Type 170 controller and Type 222 loop detector cards connected to duplex inductive loops in each of the three lanes at each site. Figure shows a typical unit.

A view of the back side of a typical cabinet at atypical CAWS traffic monitoring station is shown in Figure 3.2.1.2. The top unit is Caltrans standard Type 170 traffic control computer. Immediately below it is the Type 222 loop detector card cage (Card File) which contains three Sarasota GP6 or equivalent loop detector cards. Each card handles the two loop detectors in a lane – lead and trail. They are usually set in pulse mode, in which they produce a 25 ms pulse each time a vehicle is detected over one of the loops. The binary (open collector, +24V pull-up) outputs of the cards are inputs to the 170 controlled via the large connector on the right side of the back of the unit.

The unit below the card cage is the power supply for the 170 and the 222 loop detectors. It provides +24 VDC for the loop detectors, and +5, +24 and +/- 12 VDC for the 170 controller.



Figure 3.2.3.1. Inside of Type 334c control cabinet containing CAWS traffic monitoring equipment.

In our inspection of most of the cabinets of the CAWS, we found the wiring to be neat and well-labeled, and all components in each cabinet installed consistently. The one exception was the phone circuit wiring into some of the cabinets, which can be seen at the top right of Figure 3.2.3.1. This was inconsistent, and in several cases, we noticed that the circuit shields had not been grounded at the cabinet. While the circuits may have been grounded back at the demarcation box, possibly several thousand feet away, the lack of a local ground can cause serious noise problems when terminated at the 170 modem.

The sole speed measurement mechanism used in the CAWS are duplex inductive loops installed in each lane. Site monitored between one and five lanes, with three being the norm on I-5. A total of 216 inductive loops are connected to the CAWS. 8'x8' rectangular loops are used, as highlighted in Figure 3.2.3.2. The usual separation of the duplex loops is 20 feet, although variations from 16 to 30 feet were observed at various locations in the CAWS. It was not possible to verify if the loop separation distances has been correctly calibrated at individual traffic monitoring sites. However, speeds reported by the TMS computer as recorded in the TMS log files usually seemed reasonable. At the French Camp Slough count station that we used as a Before-CMS monitoring site, the loops had been incorrectly connected in series and the separation distance was much different than had been assumed (16 feet).



Figure 3.2.3.2. Duplex inductive loops installed in each lane for speed measurement at each traffic monitoring station.

The Type 170 controller at each traffic monitoring station calculates the speed of each vehicle from the time of flight between the two detectors in each lane, and reports the average of the vehicle speeds and counts in each lane over a polling period of 50 seconds. Since we were not permitted to inspect the source code for the speed monitoring program running on the 170 controller, our knowledge of how it performs the speed computations and communications were gleaned from our detailed inspection of the TMS source code, which we were permitted access to. Aside from our careful monitoring of the Mathews Road (site 1A) and El Dorado (site 1B) traffic monitoring stations, which we used as evaluation test sites, we also performed a sample site inspection of the Roth Road traffic monitoring station. At Roth Road, we briefly placed the 170 controller in test mode and observed vehicle-by-vehicle speeds on the LED display. We compared reported vehicle speeds with results from a LIDAR speed measurement gun provided by the District, and found that the site was measuring speeds approximately 5% higher than those reported by the LIDAR gun. We checked the loop separation distance stored in the controller and found it to be 20 feet for all lanes. This suggests that the site had not had its loop separation distances individually calibrated, and the default values were still in use. The physical loop separation distance was measured at approximately 19 feet in this case, although we are aware that the inductive separation can be different than physical distance due to small differences in the loop installation.

In our experience during this study, the loop detectors were the most problematic of all sensors, both for the evaluation system and the CAWS itself. Loops were found to be susceptible to occasional false triggering from adjacent lanes, or failures to trigger. Sensitivities were usually set to 5 as the default value recommended by the loop detector card manufacturer, but in our experience, much lower sensitivity settings were required to prevent false triggering, typically 2 or 3. Problems with the loops including failures of Type 222 detector cards at the evaluation test sites were common, and became a source of our frequent requests for assistance from district maintenance personnel (which diligently responded). But this suggests that similar problems were being encountered throughout the CAWS, with or without the immediate knowledge of the CAWS system operators, since partial failures or calibration drift can go unnoticed in the period average speed data reported by the traffic monitoring sites.

3.2.4 Changeable Message Signs (CMS)

The CAWS system uses Model 500 incandescent Changeable Message Signs (CMS). (These were eventually upgraded to LED panels.) CMS 1 is shown in Figure 3.2.4.1. We monitored this CMS as part of our evaluation of driver response. The two surveillance cameras on the mast in front of the CMS were installed by the evaluators to monitor the actual CMS message and the local traffic and visibility.



Figure 3.2.4.1. CMS 1, located near County Hospital Road (day on left, ADVISE 45 MPH Message in middle, dusk on right).

Base on our observations and interviews with district maintenance personnel, we were not aware of any significant problems with the CAWS CMSs during our period of evaluation. A persistent problem with occasionally “stuck-on” or burned-out bulbs was observed, which can be seen in the dusk (right) photo of Figure 3.2.4.1. This problem was eliminated following a major panel replacement in November 2003, just prior to the first full fog season considered in the driver behavior study, as captured by our CMS verification camera in Figure 3.2.4.2.



Figure 3.2.4.2. CMS 1 panel replacement, recorded by our CMS verification camera on Nov. 17, 2003.

3.2.5 Qualimetrics Remote Weather Monitoring Stations

The most technically sophisticated components of the CAWS are the nine remote weather monitoring stations. These were designed and installed by Qualimetrics Inc. (now All-Weather Incorporated of Sacramento, California, <http://www.allweatherinc.com/index.html>). Each is equipped with a full complement of meteorological instruments, including a forward-scatter visibility sensor, anemometer, barometer, tipping-bucket rain gauge, thermometer, relative humidity sensor, wind direction sensor, and day/night sensor. Of the many instruments at each remote weather station, only the visibility sensor, day/night sensor, relative humidity sensor, and day/night sensor are used by the CAWS.

Weather Station 4 on I-5 is shown in Figure 3.2.5.1. The proximity of the weather stations to the roadway enhanced the relevance of the fog measurements, since fog is a highly localized phenomenon.



Figure 3.2.5.1. Weather Station 4 on Interstate 5.

Immediately following Weather Station 4 are four visibility distance verification placards installed by District staff in anticipation of the installation of a CCTV surveillance system which was intended to be added to the CAWS in 1997. Marked distances were 100, 200, 300 and 500 feet. These are shown in

Figure 3.2.5.2. The placards would have provided a secondary means for verification of the visibility distance reported by the visibility sensor at WS 4. However, the CCTV system was never installed.



Figure 3.2.5.2. Visibility distance reference placards installed south of WS 4 by Caltrans District 10 personnel for manual verification of local visibility.

According to their specifications, all the weather instruments are very accurate, as they are actually “airport” AWOS (Automated Weather Observation System) components. It was not possible to verify this, but we have no reason to believe otherwise. Excellent documentation was provided by the manufacturer. However, the instruments required diligent maintenance and recalibration. The system was warranted for only one year, and no maintenance agreement was arranged with the manufacturer.

Of greatest importance to the CAWS were those instruments required for detection of fog. These were the Model Z004510 forward scatter visibility sensor, the Model 83339-A day/night detector, and the Model 5140 temperature/humidity probe. The visibility sensor and temperature/humidity sensor are shown in Figure 3.2.5.3. The humidity probe was required for activation of the CAWS since on fog is detected, and fog is reported by the QCMS system only when, in addition to visibility thresholds, relative humidity is above 75%. The day/night sensor is required since two different fog measurement algorithms are used to translate the extinction coefficient actually measured by the visibility sensor in to a visibility distance. These formulas are difference for day or night illumination. They are described in detail in the Driver Response Analysis of this report.



Figure 3.2.5.3. Qualimetrics Model Z004510 forward scatter visibility sensor (center) and Model 5140 temperature/humidity probe (left), installed at each remote weather station in the CAWS.

The visibility sensor required the most frequent service (once a month according to the manufacturer's manual), due to the need to periodically clean the windows on the two emitters and two detectors, seen in Figure 3.2.5.3. In addition, frequent recalibration was recommended, since the detector was prone to drift with time. Each of the emitters and detectors contained heaters to prevent condensation forming on the optics. According to the District maintenance staff, the most common failure items in the weather system were the heaters in the visibility sensors.

One infrequent but often unnoticed problem was the day/night sensor. We were aware of two failures, but a more common problem is shown in Figure 3.2.5.4. The aperture of the sensor was an ideal home for spiders, and dense webs or egg sacs were found in two sensors. Since the small photocell window was difficult to access, it was not a scheduled maintenance item, and the day/night sensor was not usually checked. If the day/night sensor is blocked, the QCMS system will still report visibility readings, but they are based on night calculations which can differ significantly from the correct daytime readings.



Figure 3.2.5.4. Day/night sensor blocked by spider egg sac.

3.3 Examination of the CAWS Response to Traffic and Weather Events

3.3.1 Activation Case Histories

Since it was initially enabled in November 1996, the nine CMSs of the CAWS have been activated a large number of times. 87 distinct events in which the CAWS system activated were recorded during the two years of our driver behavior study. Records of activations of each CMS by date and type over the last 14 months of our study period are shown in Table 3.3.1.1. Each count in this table represents one “event” which may have consisted of several difference messages over a period of several hours. This table does not include manual activations of individual CMS’s for test or special driver information purposes.

The cases cited below represent situations in which we learned specific aspects of the CAWS control strategy, including behaviors that were inconsistent with the general understanding of how the system should respond to traffic or weather events in the field. In several cases, as discussed below, these motivated in-depth analysis of the Signview or TMS software source code, in an effort to explain our observations.

Table 3.3.1.1. Activations of CAWS during study period.

Month	CMS1				CMS2				CMS3				CMS4				CMS5				CMS6				CMS7				CMS8				CMS9			
	Fog	Traf	Wind	Amber	Fog	Traf	Wind	Amber	Fog	Traf	Wind	Amber	Fog	Traf	Wind	Amber	Fog	Traf	Wind	Amber	Fog	Traf	Wind	Amber	Fog	Traf	Wind	Amber	Fog	Traf	Wind	Amber	Fog	Traf	Wind	Amber
Jan-04	8	1	0	0	8	1	0	0	7	2	0	0	9	4	0	0	7	5	0	0	7	2	0	0	8	4	0	0	9	4	0	0	5	4	0	0
Feb-04	1	2	2	0	1	2	2	0	2	3	2	0	1	5	5	0	0	5	3	0	0	1	1	0	0	3	1	0	1	3	1	0	0	3	1	0
Mar-04	1	4	0	0	2	4	0	0	2	4	0	0	1	6	0	0	0	5	0	0	1	0	0	0	1	5	0	0	0	5	0	0	0	4	0	0
Apr-04	0	2	2	1	0	3	1	0	0	2	2	1	0	1	3	0	0	1	1	1	0	5	0	0	0	5	0	0	0	4	2	0	0	2	1	0
May-04	0	2	0	0	0	3	0	0	0	7	5	0	0	10	6	0	0	6	0	0	0	3	1	0	0	5	1	0	0	4	1	0	0	4	0	0
Jun-04	0	1	0	0	0	2	1	0	0	3	1	0	0	9	3	0	0	8	0	0	0	3	0	0	0	6	1	0	0	8	3	0	0	8	0	0
Jul-04	0	2	0	0	0	6	0	0	0	6	0	0	0	12	1	0	0	9	0	0	0	3	0	0	0	7	0	0	0	7	0	0	0	8	0	0
Aug-04	0	2	0	1	0	4	0	1	0	4	1	1	0	5	0	1	0	10	0	1	0	3	0	1	0	12	0	1	0	12	0	1	0	11	0	1
Sep-04	0	5	1	0	0	5	1	0	0	4	2	0	0	6	2	0	0	7	0	0	0	3	0	0	0	8	0	0	0	9	1	0	0	8	0	0
Oct-04	0	1	1	0	1	2	1	0	2	2	1	0	1	3	1	0	0	3	1	0	0	3	1	0	0	4	0	0	3	3	1	0	0	3	0	0
Nov-04	8	0	0	0	11	0	0	0	9	2	0	0	11	4	2	0	9	4	0	0	7	2	0	0	3	6	0	0	11	6	0	0	11	6	0	0
Dec-04	11	3	0	1	12	3	3	1	13	1	1	1	12	5	3	1	13	5	3	1	9	2	0	1	1	4	0	1	15	7	2	1	12	6	0	1
Jan-05	6	0	2	1	10	1	1	1	8	1	1	1	6	1	0	1	3	1	0	1	7	0	0	1	0	0	0	1	9	0	2	1	5	0	0	1
Feb-05	4	0	0	0	0	0	0	0	8	1	0	0	7	5	0	0	9	5	0	0	6	10	0	0	7	11	0	0	9	9	0	0	9	7	0	0
Mar-05	2	2	0	1	0	2	0	1	3	2	0	1	3	2	0	1	3	2	0	1	3	28	0	1	4	23	0	1	4	3	0	1	3	3	0	1
Total	41	27	8	5	45	38	10	4	54	44	16	5	51	78	26	4	44	76	8	5	40	68	3	4	24	103	3	4	61	84	13	4	45	77	2	4

3.3.2 Speed-Related System Response

For traffic (speed) activations of the CAWS, a progressive speed warning strategy is implemented to alert drivers of slow or stopped traffic ahead, possibly beyond their sight distance. This is potentially a valuable asset in fog situations in which sight distances are limited. Speed-related activations override fog activations, recognizing the priority of alerting drivers of an impending traffic disturbance over a stock fog-related speed advisory. The TMS computer generates speed activation triggers for the Signview computer when speeds below 35 (SLOW TRAFFIC AHEAD) and 11 mph (STOPPED TRAFFIC AHEAD) are detected in at least one of the lanes at an appropriate speed monitoring station, except if a detection error is reported. However, the TMS software inhibits activation a warning message if any lane at a reporting site registers a speed greater than or equal to 50 mph, regardless of the speeds reported in the other lanes. The CMS immediately prior to the one displaying the warning message will display "HIGHWAY ADVISORY AHEAD" as an advanced notice to drivers to watch for the actual warning message on the following CMS.

For system operation after the direct year of operation (to be explained below), this strategy was found to be effective and generally well-designed for the through sections of I-5 and SR-120. Problems were usually traceable to inoperative, intermittent, or possibly poorly calibrated loop detectors at speed monitoring stations, and non-optimal mappings between speed stations and the CMS's that they can potentially trigger. Communications errors were also found to be not uncommon with the star-configured multi-drop modem network, which often left at least one string of 5-7 speed monitoring stations out of contact with the TMS computer. It may be noted that communications is carried on leased telco) Pacific Bell) lines, and communications faults were most often attributed to telco infrastructure issues or damage to physical communications components such as demarcation boxes.

This subsection presents selected cases in which the CAWS system did not activate predictably, and the behavior was not due to hardware or infrastructure problems. These cases were of critical importance for the operational analysis, since they ultimately revealed details of the control strategy that were not consistent with the original design objectives, and may not have been known to the system operators. In each case, warning messages were automatically displayed by the Signview computer in response to speed data collected and processed by the TMS computer. As pointed out above, these messages superseded all other messages displayed by the CAWS, either automatically or manually generated. Most responses were triggered by non-recurrent traffic congestion. Each case is identified by the date of occurrence. Excel spreadsheets were prepared from TMS speed log files and from Signview/CAWS log files. During this period, the TMS normally generated log entries at 15-minute intervals when no activation has been triggered at a site, and more frequently once a trigger condition has been detected and a warning message has been activated.

3.3.2.1 November 14, 2003

A single-vehicle accident occurred on I-5 southbound at 6:00 am, approximately halfway between the San Joaquin River Bridge and the SR-120 underpass. The weather was clear, roadway conditions normal, and illumination was night/dawn with streetlights. The vehicle rolled over after hitting a metal light pole. One person was injured in this accident. The responding CHP officer noted that the primary cause of this accident was an unsafe turn by the vehicle.

Shortly afterward, at 6:03 am, there was an accident on SR-120 westbound in the same area. The same CHP officer responded to this accident and reported that an object in the road caused this incident. The object was most likely debris from the previous accident on I-5. The first vehicle hit an object and proceeded to contact the front right corner of a second vehicle, which had previously stopped. Figure 3.3.2.1¹ illustrates the approximate location of the two accidents. The pink rectangles indicate the approximate locations of speed monitoring stations 9A and 9B on SR-120 westbound. The milepost indicated on the CHP report for the first accident was “0.1 miles north of 5 SJ R14.607 or 110 feet south of W/B SR120.” The CHP officer noted that the vehicle needed to be towed away. It is possible that congestion occurred as a result of the overturned vehicle blocking the roadway.

¹ The aerial image in Figure 3.3.2.1 is a montage of satellite photos obtained from the Microsoft TerraServer web site, and may be as old as 1994. Significant work has been done to SR-120 westbound to the I-5 north interchange since this photo was taken.

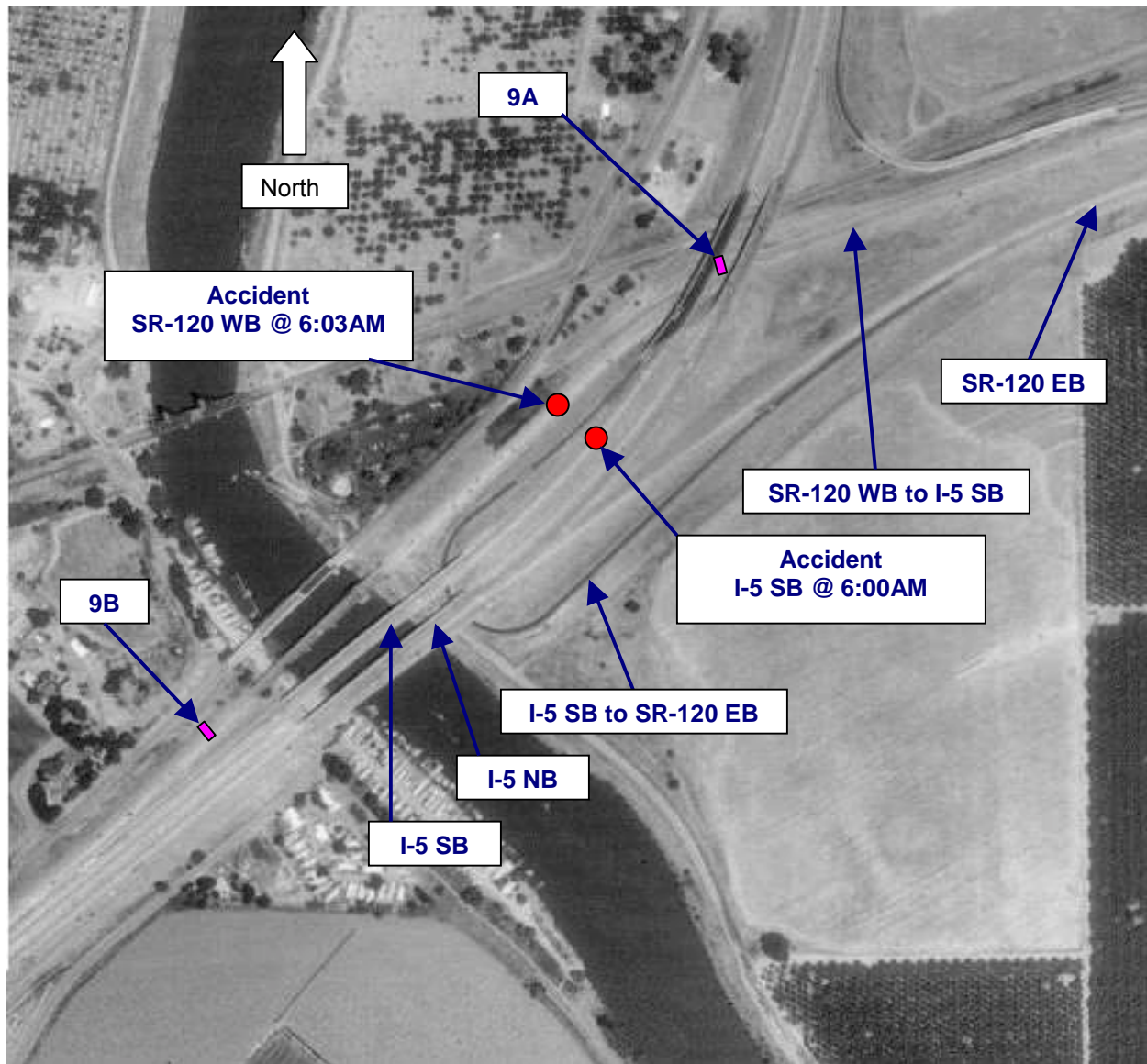

Figure 3.3.2.1. Accident Locations (2004-11-14).

The exact location of the light pole referred to in the first accident report is unknown although the vehicle may have lost control around the I-5 bend. The traffic data from the TMS (speed monitoring) computer in the D-10 Traffic Management Center (TMC) showed that there were no significant speed disturbances before or after the 'Y' section on I-5 during this time. However, SR-120 traffic slowed down abruptly at speed station 9A. Only a minor decrease in speed was detected at speed site 9B which could be attributed to traffic regaining speed after passing the second accident. The speed data for sites 9A and 9B are shown in Figure 3.3.2.2 and Figure 3.3.2.3, respectively.

All time references associated with this event are synchronized with the times in the Signview log file. The TMS speed log entries for this day were originally approximately four minutes ahead of the Signview computer clock. These were corrected by reference to common events in the respective log files.

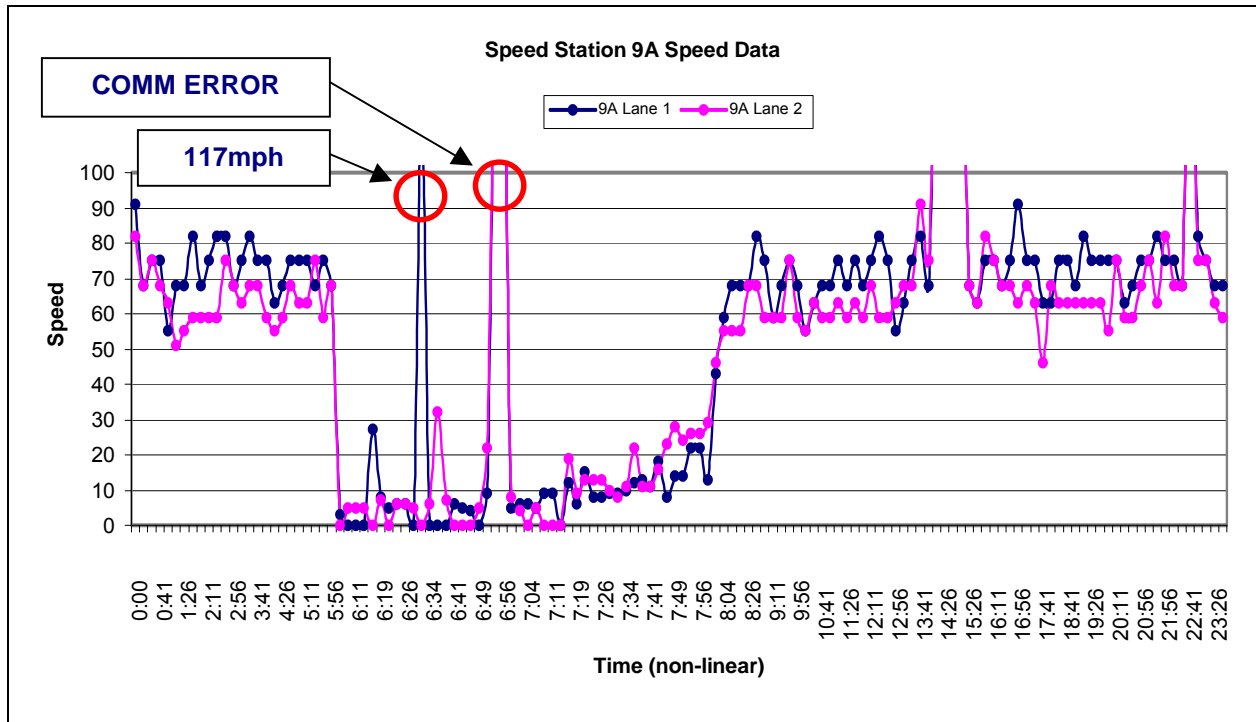

Figure 3.3.2.2. Speed Site 9A.

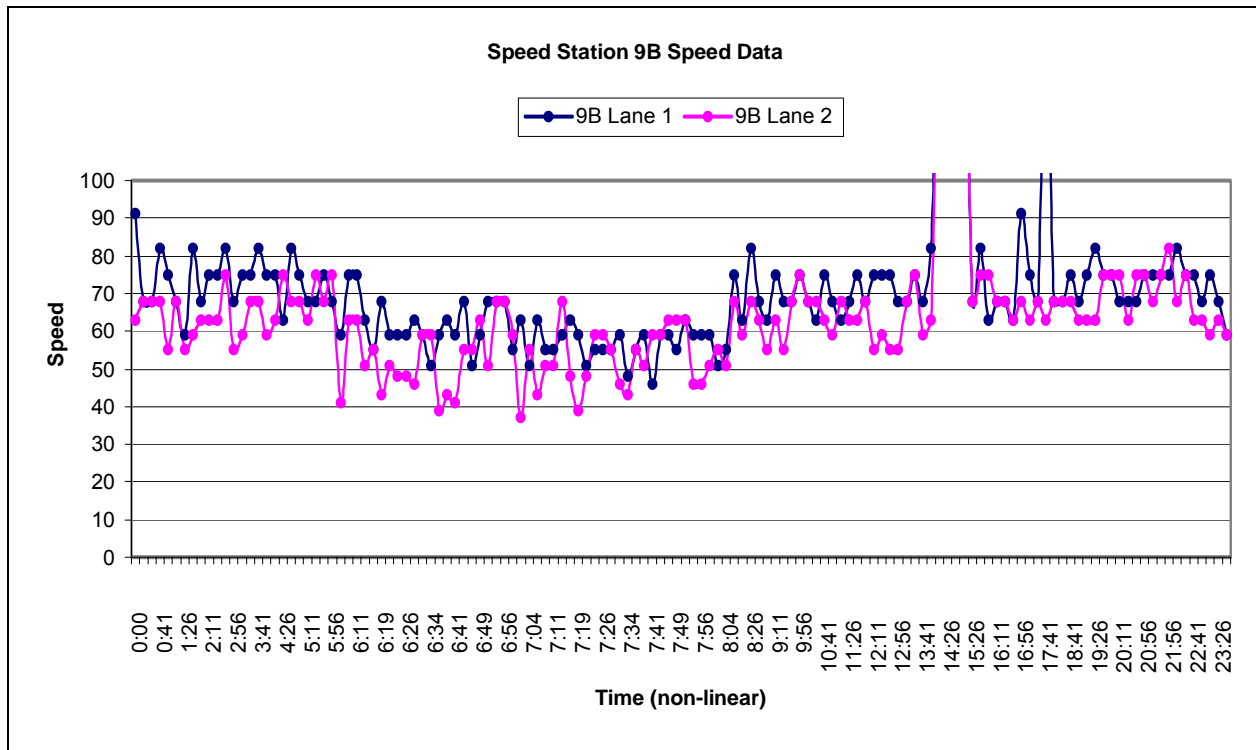

Figure 3.3.2.3. Speed Site 9B.

As previously mentioned, speed warning activations are triggered at thresholds of 35 (SLOW TRAFFIC AHEAD) and 11 mph (STOPPED TRAFFIC AHEAD). However, by observation of many activation incidents, and confirmation from the computer source code, we found that the TMS software inhibits activation a warning message if any lane at a reporting site registers a speed greater than or equal to 50 mph, regardless of the speeds reported in the other lanes. This explains why no CMS activation occurred even though traffic was stopped in two of the five lanes at Site 9A in the I-5 SR-120 merge section. This design decision may have been originally implemented out of concern for faulty speed data from the 222 loop detectors interfaced to the 170 controller. This may have been necessary since the system designers anticipated the unreliability of inductive loops when used for automated response generation. Indeed, at any time for which speed logs were available, one or more of the loop detectors at the 36 speed monitoring sites were non-functional or malfunctioning. The TMS software invalidates speed data for a particular lane if the associated volume data is reported as zero. Detection actions are also inhibited in cases of loss of communications or communications errors. False activations due to partial detection or communications errors are therefore prevented, although these same conditions might incorrectly inhibit an otherwise correct activation.

We found from examination of the TMS and Signview computer source code that communications failures are reported by the speed monitoring sites as 240 mph (the maximum code-able speed), and detection errors of any type, as well as speeds equal to or above 150mph, are reported as "ERR". In the plots below, for numeric consistency, all "ERR" speed conditions from the TMS log files have been converted to 150mph speeds. Spikes in the speed data plot below actually represent "ERR" conditions.

The Signview log file, shown graphically in Figure 3.3.2.4, indicates that no messages were activated for any of the Changeable Message Signs (CMS) on I-5 (CMS 1 through CMS 5). This lack of message activation is consistent with the TMS speed data log file. Speed stations 9A and 9B were capable of activating CMS 9 during this period. CMS 9 should have activated due to the station 9A condition, but was apparently inhibited by the "no warning if any lane over 55" algorithm. Figure 3.3.2.2 shows that speeds at station 9A fell to 0 mph, well under the 11 mph or below threshold used to activate the "STOPPED TRAFFIC AHEAD" message.

As shown in Figure 3.3.2.4, there are several breaks in the activation of CMS 9. The "STOPPED TRAFFIC AHEAD" message was issued by CMS 9 several times in succession with interruptions between each issue. This intermittency was attributed to erroneous speed data sent from 170 controller. As stated earlier, the TMS software inhibits activation from a loop site if it receives a speed report of 50 mph or greater in any lane at that site. The "STOPPED TRAFFIC" message was interrupted during this period because of intermittent erroneous readings of 117 mph in lane 1 at 6:31 am.

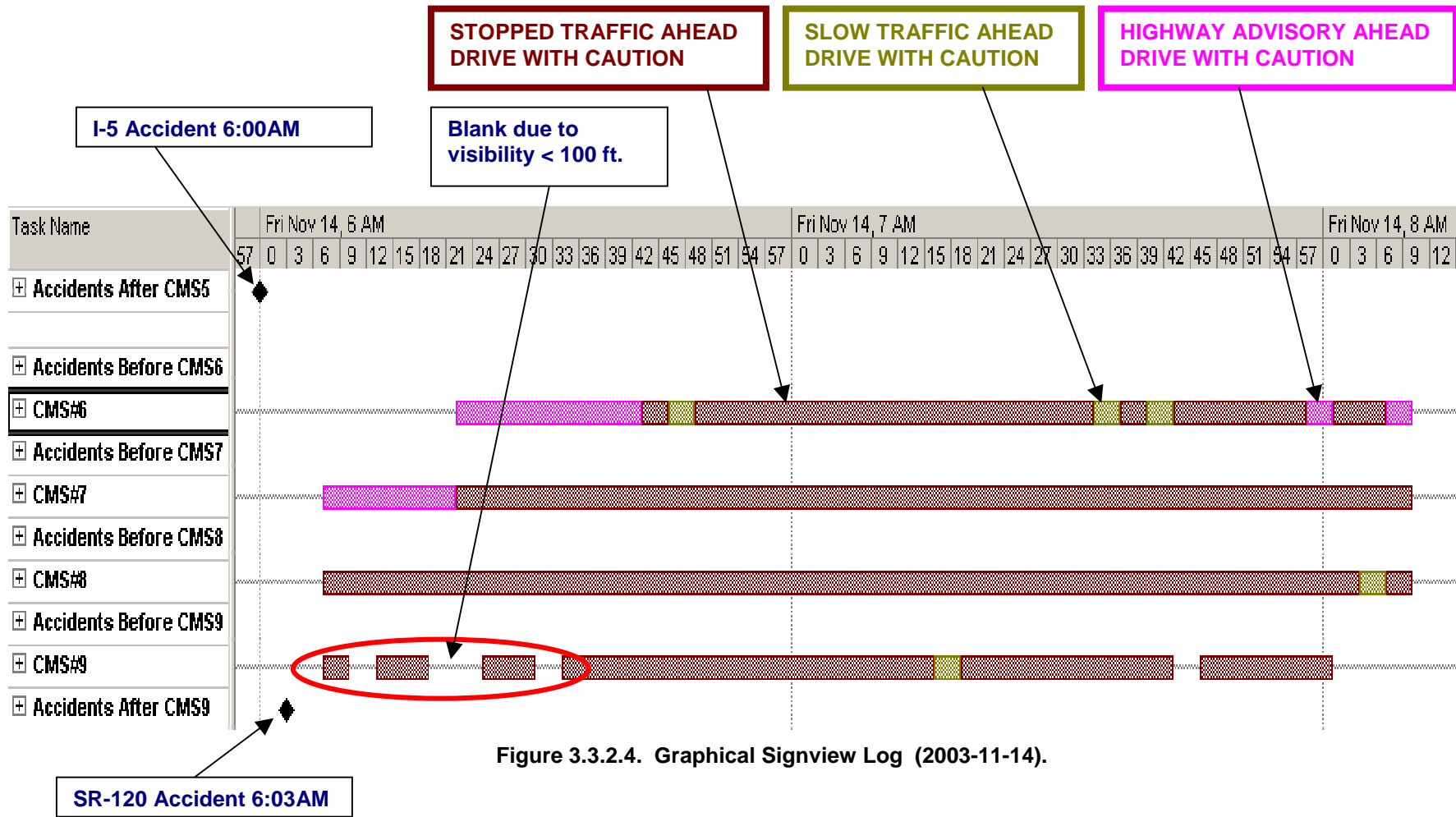

Also of note during this event was the lack of response from conditions in lanes 4 and 5 (slow lanes in merge section) at speed station 9E. This station appeared to be reporting data only from the three fastest lanes. This could have resulted from malfunctioning 222 loop detector cards, but is more likely due to the five-lane speed monitoring station 9E being configured the same as other sites which monitored only three lanes. The TMS algorithm does not distinguish between two, three or five lane sites. The zero values reported by the 170 controller in lanes 4 and 5 at station 9E could have caused a false activation of the CMS. However, it is unknown what volume (or count) data the 170 controller was reporting during this period. Since the TMS software invalidates speed data for a particular lane if the associated volume data is read as zero, it was possible that the speed data for Lanes 4 and 5 were completely ignored. Moreover, the 5-lane speed site 9E seldom causes a CMS activation since the fast lanes are through lanes, not merging with I-205, which rarely slow below 50 mph even when traffic in lanes 1 and 2 is stopped (frequently).

Zero values were also reported at site 9E in lanes 4 and 5 starting at 6:45am on 8-26-2003. These zero values occurred after maintenance attempted to solve a previous communications problem at this site. This problem was eventually repaired at 1:15pm 12-09-2003. Even during stopped traffic conditions, as indicated by zero speed measurements in some lanes, the activation algorithm rarely displayed a stopped traffic message on CMS 9 and CMS 5 since this required that traffic in all lanes fall below 50 mph. CMS 8 and CMS 4 would display the preemptive message "HIGHWAY ADVISORY AHEAD" when CMS 9 or 5 were activated, noting again that this required that the speeds in all lanes fall below 50 mph. When speeds in lanes 1-3 eventually dropped below 50 mph at site 9E, other sites south of the 'Y' provided the activation justification for the stopped traffic message. Another nearly identical case occurred a few days later on 11-29-2003 at 2:00 pm.

Table 3.3.2.1. Raw Speed Data.

Original Time	Shifted Time	STA 9A Lane 1	STA 9A Lane 2	STA 9B Lane 1	STA 9B Lane 2
5:45	5:41	75	59	75	68
6:00	5:56	68	68	68	75
6:11	6:07	3	0	59	41
6:14	6:10	0	5	75	63
6:15	6:11	0	5	75	63
6:17	6:13	0	5	63	51
6:20	6:16	27	0	55	55
6:23	6:19	8	7	68	43
6:26	6:22	5	0	59	51
6:29	6:25	6	6	59	48
6:30	6:26	6	6	59	48
6:32	6:28	0	5	63	46
6:35	6:31	117	0	59	59
6:38	6:34	0	6	51	59
6:41	6:37	0	32	59	39
6:44	6:40	0	7	63	43
6:45	6:41	6	0	59	41
6:47	6:43	5	0	68	55
6:50	6:46	4	0	51	55
6:53	6:49	0	5	59	63
6:56	6:52	9	22	68	51
6:59	6:55	255	255	68	68
7:00	6:56	255	255	68	68
7:02	6:58	5	8	55	59
7:05	7:01	6	4	63	37
7:08	7:04	6	0	51	55
7:11	7:07	5	5	63	43
7:14	7:10	9	0	55	51
7:15	7:11	9	0	55	51
7:17	7:13	0	0	59	68
7:20	7:16	12	19	63	48
7:23	7:19	6	9	59	39
7:26	7:22	15	13	51	48
7:29	7:25	8	13	55	59
7:30	7:26	8	13	55	59
7:32	7:28	9	10	55	55
7:35	7:31	9	8	59	46
7:38	7:34	10	11	48	43
7:41	7:37	12	22	55	55
7:44	7:40	13	11	59	51
7:45	7:41	11	11	46	59
7:47	7:43	18	16	59	59
7:50	7:46	8	23	59	63
7:53	7:49	14	28	55	63
7:56	7:52	14	24	63	63
7:59	7:55	22	26	59	46
8:00	7:56	22	26	59	46
8:02	7:58	13	29	59	51
8:05	8:01	43	46	51	55
8:08	8:04	59	55	55	51
8:11	8:07	68	55	75	68

3.3.2.2 July 6, 1997

July 6, 1997 was a heavy traffic day due to the Independence Day holiday. On this Sunday, heavy traffic congestion lasted an unusual duration of approximately seven hours. The Signview computer log files indicate that there was severe congestion on SR-120. The holiday traffic was compounded by an accident that occurred at 7:30 pm in the merge zone. According to TASAS data, this accident occurred in a construction zone in the southbound I-5 and SR-120 merge area. The accident was a sideswipe involving two pickup trucks, which resulted in no injuries. The weather was clear, the road surface was dry, and no unusual roadway conditions were reported. The accident occurred during daylight hours.

The system appears to have turned off at 7:30 pm, which coincides with the time the accident occurred. A graphical representation of the Signview log files is depicted in Figure 3.3.2.5. This plot reveals the presence of two anomalies that warranted further investigation.

The first anomaly occurred during the 15-minute interval between 1:15pm and 1:30pm. A “STOPPED TRAFFIC” message was displayed on CMS 6 while a “TRAFFIC ADVISORY AHEAD” message and two “STOPPED TRAFFIC AHEAD” were displayed on CMS 7 through CMS 9, respectively. Drivers would normally expect to see the same or a progressively changing warning message on contiguous CMS displays throughout the CAWS area. An advisory message was designed for display on the CMS upstream of traffic congestion. In this event, the progression of messages seen by drivers traveling westbound on SR-120 was: STOPPED, ADVISORY, STOPPED, and STOPPED. The first STOPPED message seemed particularly out of place, and was eventually attributed to a fault in the original mapping of speed stations to CMS activations to be discussed later in this subsection.

The second anomaly occurred at 5:45pm. In this case, a “HIGHWAY ADVISORY AHEAD” message was displayed on CMS 8 while the remainder of the SR-120 CMSs displayed “STOPPED TRAFFIC AHEAD” messages. The progression of messages seen by drivers traveling westbound on SR-120 was: STOPPED, STOPPED, ADVISORY, and STOPPED. In this progression, the “advisory” message seemed particularly out of place. The only speed site capable of activating CMS 8 (that was actually downstream of CMS 8) was station 9B. Several speed stations upstream of CMS 8 could have activated CMS 8 during this time: 6A, 6B, 6C, 7A, 7B, and 7C. Figure 3.3.2.5 shows the progression of messages on each CMS. The color key for the message is the same as that defined in Figure 3.3.2.4.

The unusual response of the system in this and similar cases observed during the first year of CAWS operations motivated us to more closely investigate the actual system control strategy by examination of the Signview software source code². We discovered that the observed incorrect relationship between speed sites and CMS sites was due to the use of an incorrect version of the TMS mapping table, which

² The source code for the Signview software was provided by Joel Retanan of Caltrans DRI. The program was written in Borland Turbo-C 3.0.

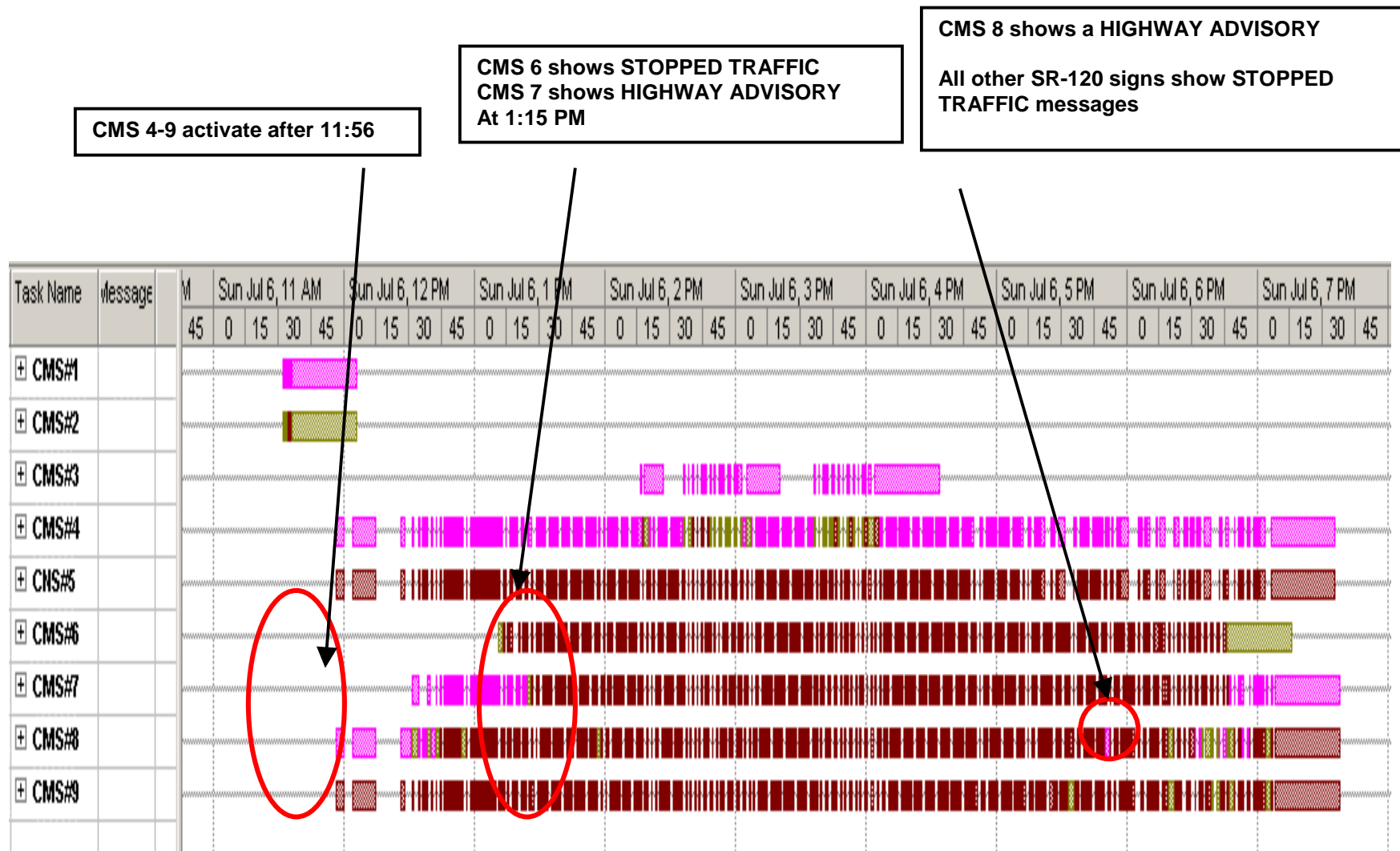

Figure 3.3.2.5. Graphical Signview Log File (1997-07-06).

incorrectly associated speed monitoring sites with CMS's. This error was eventually found to be due to a change in the site numbering convention incorporated in the final system, but the retention of the old mapping table. The error was corrected during a system software update September 29, 1997, approximately eleven months after the start of CAWS operation. A derived complete diagram of the original version of the CMS-speed station mapping is shown and described later in Figure 3.8.1.2. Figure 3.3.2.6 is a subset of this diagram which provides a close-up of the activation path for CMS 6 and 1:15 pm. The speed log files for this event show that speed station 8E delivered data to Signview at 1:15 pm which triggered the stopped traffic message on CMS 6. The corresponding data from speed site 8E is shown in Figure 3.3.2.7.

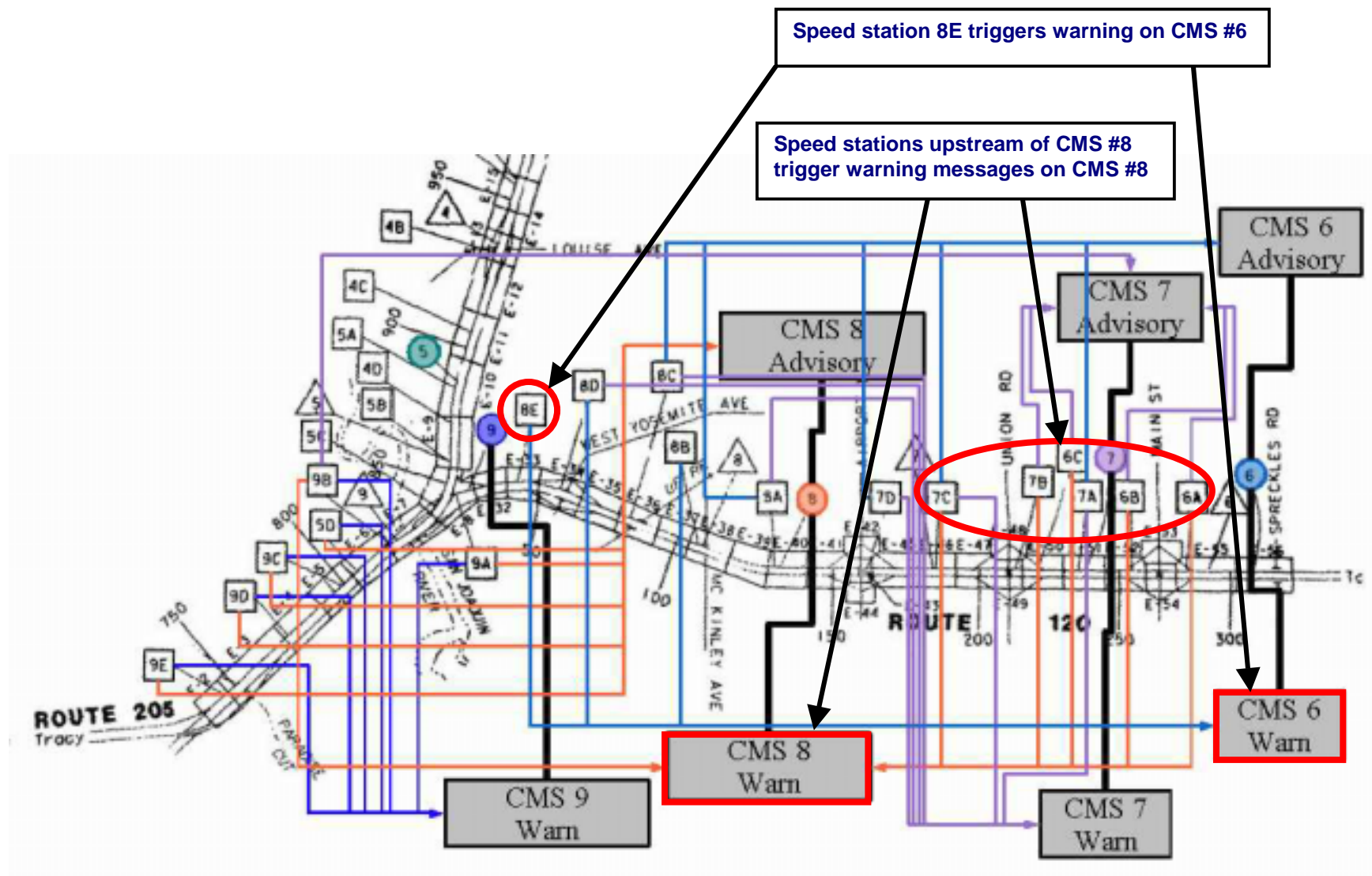

Figure 3.3.2.6. SR-120 Speed Site – CMS Mapping.

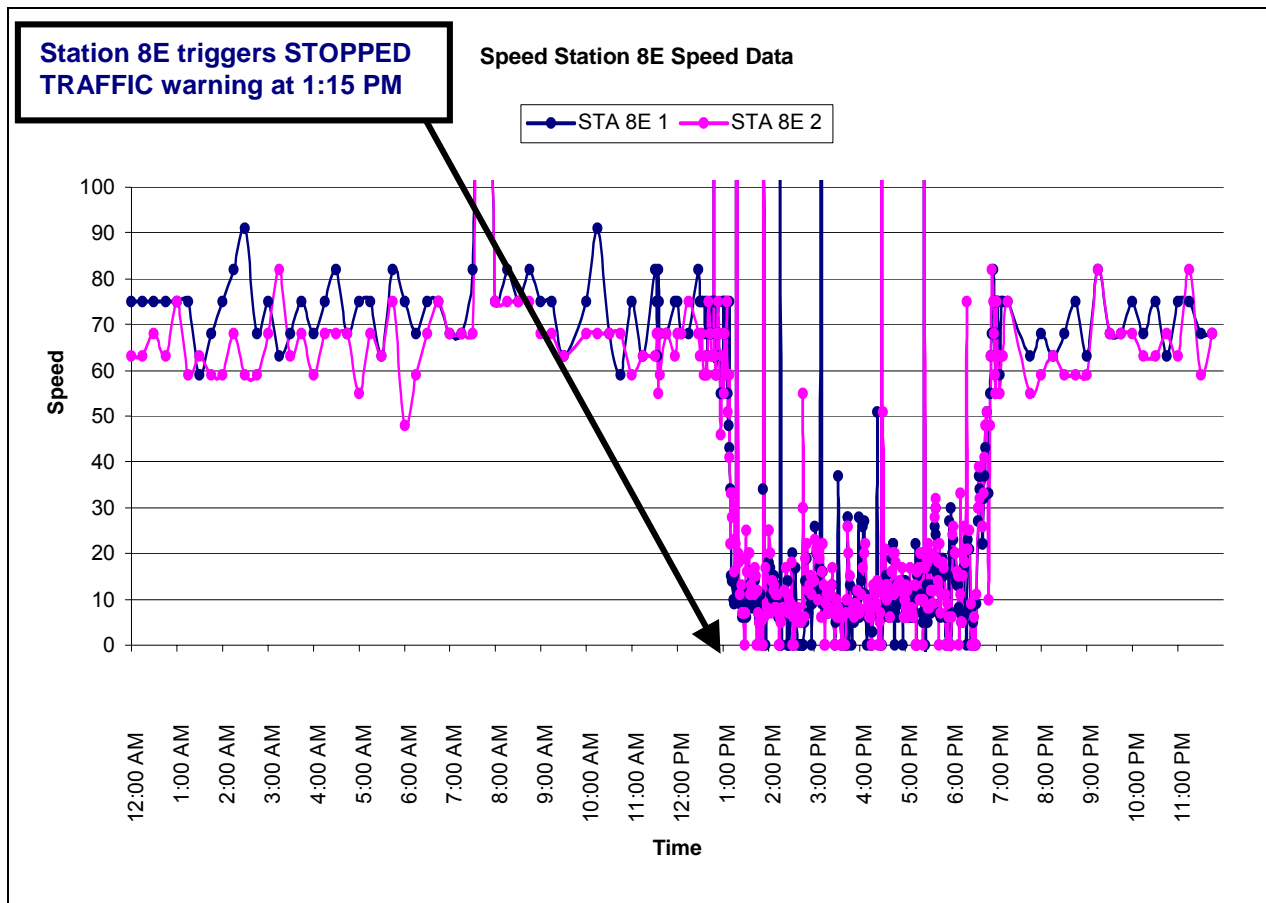
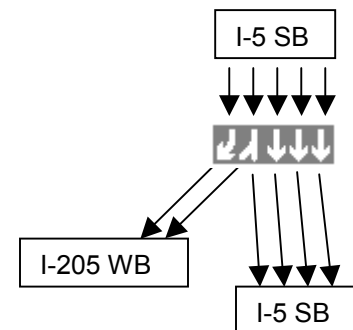

Figure 3.3.2.7. Speed Station 8E Speed Data.

On this same day, speed monitoring site 9E (the closest to the I-205 and I-5 split) showed signs of stopped traffic in lanes 4 and 5 prior to 11:15 am. This data is shown in Figure 3.3.2.8. But the system activated at 11:56 am, 41 minutes later. This delay occurred despite the stopped traffic condition in 4 and 5 at 5-lane Site 9E because lanes 1 and 2 were above 50 mph. Activation did not occur until traffic had backed up all the way to Y junction, and a slow traffic condition was detected by Site 8E.



Speed site 9E is the southern-most of four speed sites monitoring the 5-lane section after the I-5 and SR-120 merge area. Speed site 9E immediately precedes the westbound I-205 exit. If congestion occurs on I-205 and backs up into this transition section, speed site 9E is the first to detect it. Therefore, detection of slow or stopped traffic in the merge lanes at Site 9E is critical to providing advanced warning to drivers entering the I-5 / SR-120 merge zone.

The 5-lane merge zone at the convergence of I-5 and SR-120 (known as the Mossdale Y) is known from the Collision Data Analysis volume of this report to be an area of relatively higher accident rates, and was one of the original motivations for the construction of the CAWS. It appears from the TMS log data that the “inhibit if any lanes greater than 50 mph” strategy that may have been appropriate in the two or three lanes sections of the CAWS area, was inappropriate in this case, since the actual merge lanes (4 and 5) are routinely backed up due to congestion on SR-205, but are beyond the sight distance of traffic approaching from either SR-120 or I-5. Lanes 1-3 are through lanes for I-5 which typically flow at speeds greater than 70 mph. In this case, the 50 mph inhibit strategy resulted in the system’s inability to activate at the ‘Y’ due to congestion occurring only in the merge lanes.

Also, while not represented in this event, inspection of the CMS-speed-site mapping in Table 3.8.1.2 indicates that slow or stopped traffic at Station 9B, the first detection site in the (still considered part of SR-120) merge area, can trigger a warning message on CMS 9 on SR-120 but not on CMS 5 on I-5. If only Station 9B is triggered, this unlikely situation can potentially result in traffic entering from SR-120 being advised of a slowdown or stoppage ahead, while traffic entering from I-5 is not.

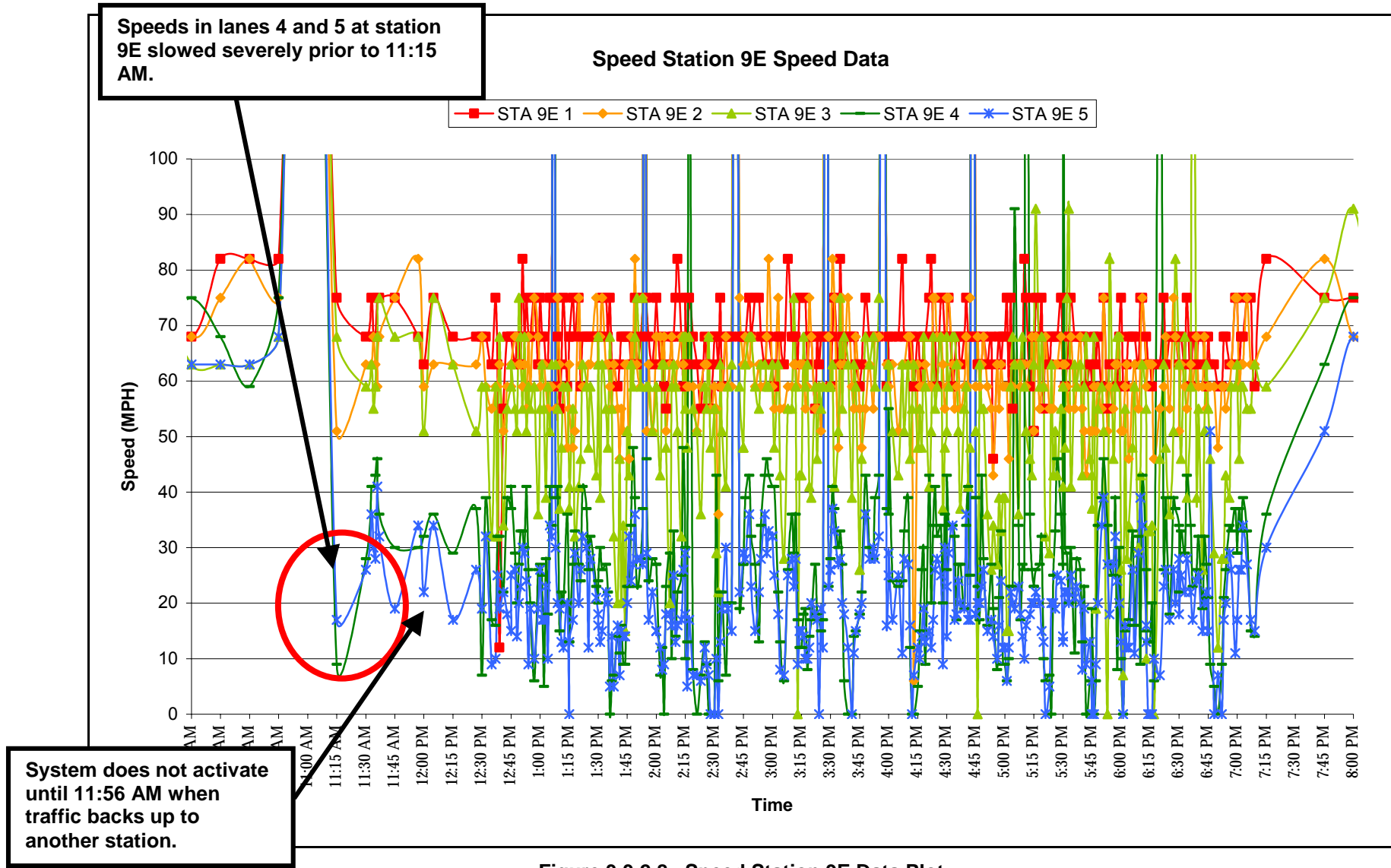

Figure 3.3.2.8. Speed Station 9E Data Plot.

3.3.2.3 TMS/Speed Station Communications Problems, Various Dates

The following are instances of communication errors between the speed stations and TMS computer. These resulted in some speed monitoring stations down for extended periods of time. Possible reasons could include communication failure between speed stations and the TMS computer, or power loss to the speed stations.

- Slow lane of speed site 5B from 3-25-04 18:45 to 6-9-04 11:30. The slow lane indicated a zero for this period. Unknown if there was a failure in the 170 controller, loop detector or if the lane was closed.
- All sites from 6-09-04 12:30 to 6-10-04 13:30
- All sites from 10-24-04 2:30 to 22:30
- All sites from 10-27-04 7:30 to 16:30
- All sites from 11-05-04 15:30 to 11-09-04 10:30
- All sites from 11-11-04 11:30 to 11-12-04 12:00
- Sites 1A, 1B, 1C, 2A, 2B, and 2C from 11-12-04 15:15 to 11-15-04 11:00
- Sites 2D, 3A, 3B, 3C, 3D, and 4A from 11-16-04 1:45 to 11-22-04 11:37
- All sites from 12-24-04 15:00 to 12-26-04 3:30
- All sites from 1-07-05 9:00 to 1-09-05 11:00
- All sites from 1-11-05 2:30 to 1-18-05 17:15
- All sites from 1-19-05 20:30 to 1-21-05 11:15
- Sites 1A, 1B, 1C, 2A, 2B, and 2C for 1-26-05 13:45 to 2-03-05 5:45
- Sites 1A, 1B, 1C, 2A, 2B, and 2C for 2-05-05 12:45 to 2-09-05 11:00
- All sites from 3-01-05 13:15 to 3-10-05 00:00
- Sites 1A, 1B, 1C, 2A, 2B, and 2C for 3-10-05 00:00 to 3-11-05 10:30

The following are instances of field device errors reported by speed stations. Field device errors are due to problems other than communications, usually related to the loop detectors at the speed monitoring stations.

- Site 8A from 10-31-04 18:45 until later then 3-31-05
- Site 1A from 12-26-04 3:30 to 12-28-04 12:00
- Site 1C from 1-18-05 19:00 to 2-07-05 11:00
- Site 1A from 2-01-05 9:45 to 2-07-05 11:00
- Site 1A from 2-13-05 19:15 to 2-15-05 21:00
- Site 1A from 3-11-05 10:30 to 3-14-05 5:30
- Site 6B from 3-30-05 13:00 until later then 3-31-05

3.3.3 Fog-Related System Response

This subsection examines selected cases in which the CAWS activated the warning signs for fog-limited visibility conditions. These cases revealed critical aspects of the system control strategy beyond the generally assumed “if fog then warning”.

There is a one-to-one relationship between weather stations and CMSs in the CAWS, with the CMS preceding the associated weather station. Each weather station is equipped with a forward-diffusion visibility sensor which reports visibility as an extinction coefficient. The QCMS computer translates the extinction coefficient into visibility in feet (or meters) based upon knowledge of the illumination level at the station provided by a day/night sensor. The QCMS reports fog-limited visibility separately from absolute visibility. The distinction between the two is that fog requires a relative humidity of greater than approximately 90%, as reported by an integrated temperature/relative humidity sensor. Therefore, three sensors must be functional and correctly calibrated at a weather station in order to report fog-limited visibility: the visibility sensor, the relative humidity sensor, and the day/night sensor. Since the CAWS does not detect visibility alone, it cannot respond to reduced visibility conditions due to dust or smoke. The system operators, and possibly the original software programmers, were unaware of this until discovered in our analysis of the Signview source code.

Three levels of fog warning are provided by the QCMS computer for each weather station, capable of activating three different warning messages for fog-visibility thresholds of 500, 200 and 100 feet. Prior to

January 2001, the CAWS displayed non-specific advisory messages for the 500 foot (FOGGY CONDITION AHEAD) and 200 foot (DENSE FOG AHEAD) thresholds. Due to a software error³, no message was displayed if visibility dropped below 100 feet. In January 2001, the 500 and 200 foot threshold warnings were changed to specific speed advisories “FOGGY CONDITION AHEAD, ADVISE 45 MPH” and “DENSE FOG AHEAD, ADVISE 30 MPH” respectively. Again, no message was displayed for visibilities below 100 feet since the error had not yet been discovered. In November 2004, following the release of our preliminary findings on system software and control errors, the messages were changed to read “FOGGY CONDITION AHEAD, ADVISE 45 MPH” for all thresholds, including visibilities below 100 feet. The text of each message can be modified by the system operators by a simple change to a configuration file used by the Signview/CAWS program.

The fog warning capabilities were considered by the system designers to be the showcase feature of the system, which defined its primary mission. When all hardware and communications were functional, the system was found to reliably generate CMS warning messages for visibilities between 100 and 500 feet. We directly monitored the CMS 1 messages, for which it appeared that the visibility of the incandescent Type 200 CMS was remarkably good, even under poor visibility conditions. However, the use of multi-page messages may have taken too long for drivers to read in dense fog. Note that at 200 feet actual visibility, a driver would only be able to read the message for two seconds or less at 66 mph. The display time for a two-page CMS message is approximately 2.5 seconds.

The polled system response delay of typically 5-6 minutes also may have weakened the credibility of the warning messages, since the advection fog common to this area can vary in density dramatically in short periods of time. The one-CMS-to-one-weather-station paradigm was probably conceived to take advantage of the local nature of fog in the CAWS area. However, the design decision to not take advantage of the multiple sources of information and generate an appropriate system-wide response eliminated the possibility of data cross-checking between sites to isolate malfunctioning detectors, and progressive and consistent warning sequences. Since each CMS message was based on only one detector, and fog density varied locally, drivers through the CAWS area were often exposed to a sequence of locally correct but contradictory messages on successive CMSs. And the dependency of fog detection on three sensors at each weather station made the system more susceptible to hardware reliability and calibration problems as the system aged.

³ This was ultimately traced to the fact that the visibility warning flags generated by the QCMS are mutually exclusive. The original programmers of the system may have incorrectly assumed that the Level 2 warning message flag would persist during a Level 3 warning.

3.3.3.1 December 2, 2003

An accident involving two vehicles occurred at 7:55 am on I-5 southbound at post mile 13.72, in the 5-lane Mossdale Y section of the SR-120 and I-5 merge, halfway between the southbound SR-120 (14.736) onramp and the southbound I-205 (12.83) offramp. No injuries were reported. A 1996 3-axle truck swerved into lane 4 from lane 5 and sideswiped a 2003 Toyota sedan. The truck was cited for section 21658 (a) of the vehicle code (unsafe lane change). The CHP officer noted that the accident occurred in daylight on dry roadway with no unusual conditions, but that the visibility was limited by fog to an estimated 300 feet at the time of the accident.

Several CMSs activated due to the fog-limited visibility, as shown in Figure 3.3.2.5, each displaying advisory messages when fog-visibility at their corresponding weather stations fell below 500 feet, and then below 200 feet. Several times during this event the fog warning messages on CMS 1 and CMS 3 were blanked when visibility fell below 100 feet. The alternating sequence seen by drivers was:

DENSE FOG ADVISE 30 MPH → BLANK → DENSE FOG ADVISE 30 MPH

Despite very low visibility, a failed relative humidity (RH) sensor at Weather Station 9 prevented interpretation as fog, so no message was displayed on CMS 9 located immediately prior to the Y on SR-120. The actual text string sent by the QCMS computer to the Signview/CAWS computer was:

```
*09 03-12-02 05:58:30 05 66.3 2.8 277 10.7 M M 1019.9 0.000 0.000
```

The red value (66.3) in the string indicates the visibility (in meters). The blue entry (05) indicates the “alarm” flag level. The date and time are the second and third fields in the string. Alarm flag level **05** indicates a NON-FOG visibility warning message of Level 2 occurred. The reading of **66.3** meters translates to 217 feet. Weather station 9 delivered NON-FOG visibility Level 1 and 2 flags from 3:17 am to 9:30 am. Visibility at weather station 9 dropped to its lowest point at 5:15 am to 47.4 meters (or 155.5 feet). However, since Signview does not activate for NON-FOG flags, no warning message was displayed on CMS 9 on SR-120. Only traffic coming from I-5 was notified of dense fog immediately before the ‘Y’ section.

A similar sensor failure occurred concurrently at Weather Station 2. Weather station 2 was operating correctly up until 5:35 am after which the RH sensor reported a negative wet bulb temperature. This changed the alarm type reported by the QCMS computer from fog to non-fog visibility during this period of dense fog. The sequence of communications strings sent by the QCMS computer to the Signview computer appear below, showing the alarm type change from fog (02) to non-fog (06) at 5:35:41 am.

```
*02 03-12-02 05:35:00 02 32.6 1.3 214 9.4 9.4 100 1027.0 0.000 0.000
*02 03-12-02 05:35:41 06 32.8 1.1 216 9.4- 46.3 1 1027.0 0.000 0.000
*02 03-12-02 05:36:00 06 32.8 1.1 216 9.4- 46.3 1 1027.0 0.000 0.000
*02 03-12-02 05:36:51 06 31.4 1.0 209 9.4 M M 1027.0 0.000 0.00
```

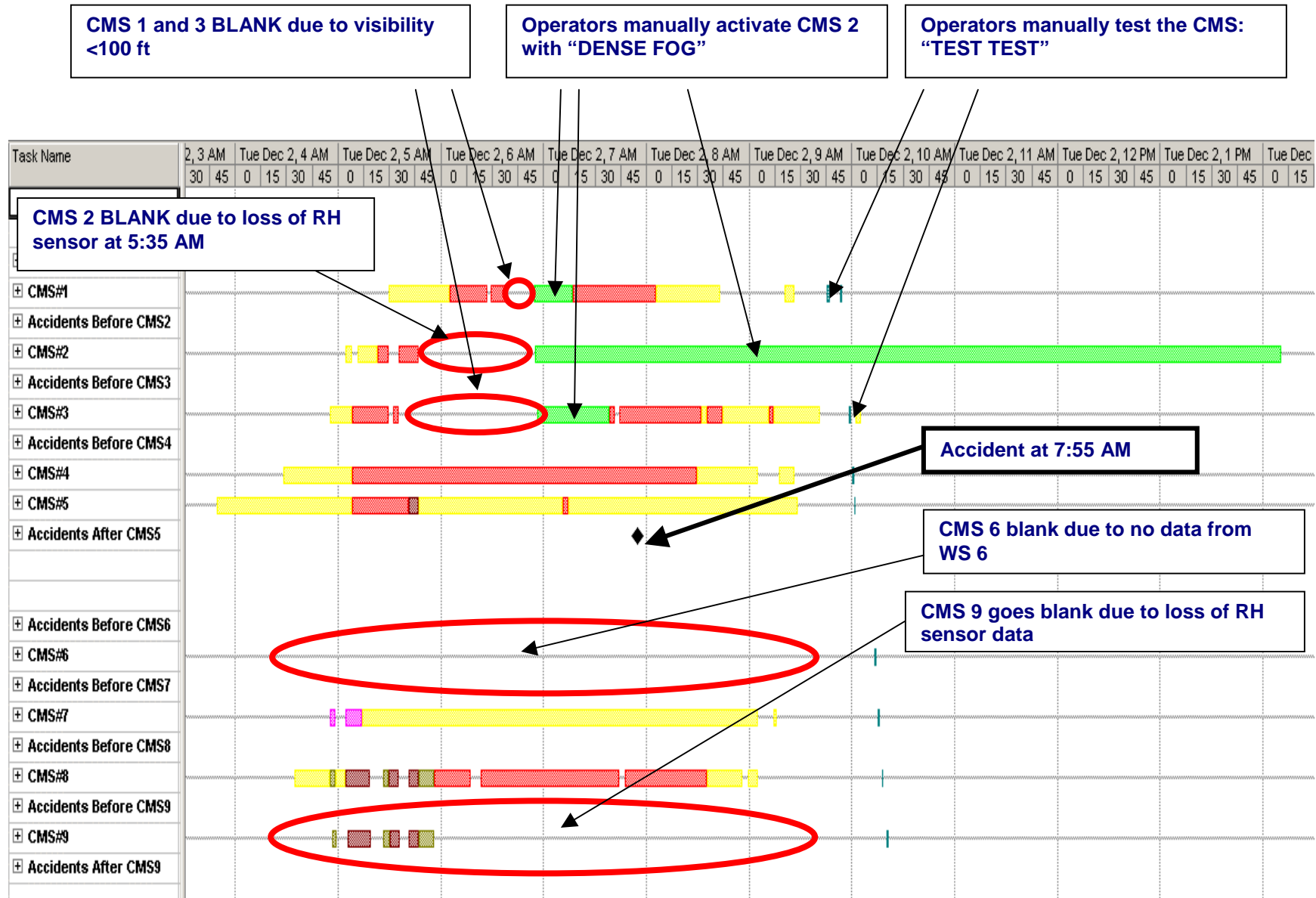

Figure 3.3.3.1. Graphical Signview Log File (2003-12-02).

During the middle of the event (approximately 6:55 am), the system operators apparently realized that CMS 1, 2, and 3 were had gone blank, unaware of that the reason was a software error. The system operators decided to take preemptive action and manually activated those CMSs with a “DENSE FOG” warning in an attempt to override the system. Starting at 9:45am, the system operators tested all the CMS connected to the system, presumably to test if Signview’s inability to display messages was possibly due to communication problems. The system operators found that their test messages displayed correctly. However, a communications problem apparently occurred with CMS 2 at approximately 9:30 that made it impossible to manually remove the “DENSE FOG” message until the problem was resolved after 2:00 pm. Visibility was clear after approximately 10:15 am.

Following the accident, the system did not activate for speed despite the slow or stopped traffic in lanes 4 and 5 at speed stations 9D and 9E, since speeds in the I-5 through lanes (1-3) did not all drop below 50 mph. In fact, the speed log file shows that no speed conditions were detected after 6:00am. At this time, the log file resumed the 15-minute logging interval. Unfortunately, the 7:45am reading was absent from the speed log file, potentially due to a full-system communications interruption. That entry would have immediately preceded the 7:55 am accident. Figure 3.3.3.2 and Figure 3.3.3.3 indicate that the system detected slow speeds before the accident occurred.

Constant zeros were reported for the two slow lanes (Lanes 4 and 5) at the southernmost speed site 9E. Because volume information is not logged by the TMS software, there is no way to tell if ‘0’ meant 0 mph or no vehicles had been detected. The system failsafe assumption in the event of no data is zero volume, which inhibits the TMS from generating a speed alarm for these lanes, despite the obviously slow or stopped traffic condition in lanes 4 and 5 due to the accident at this location.

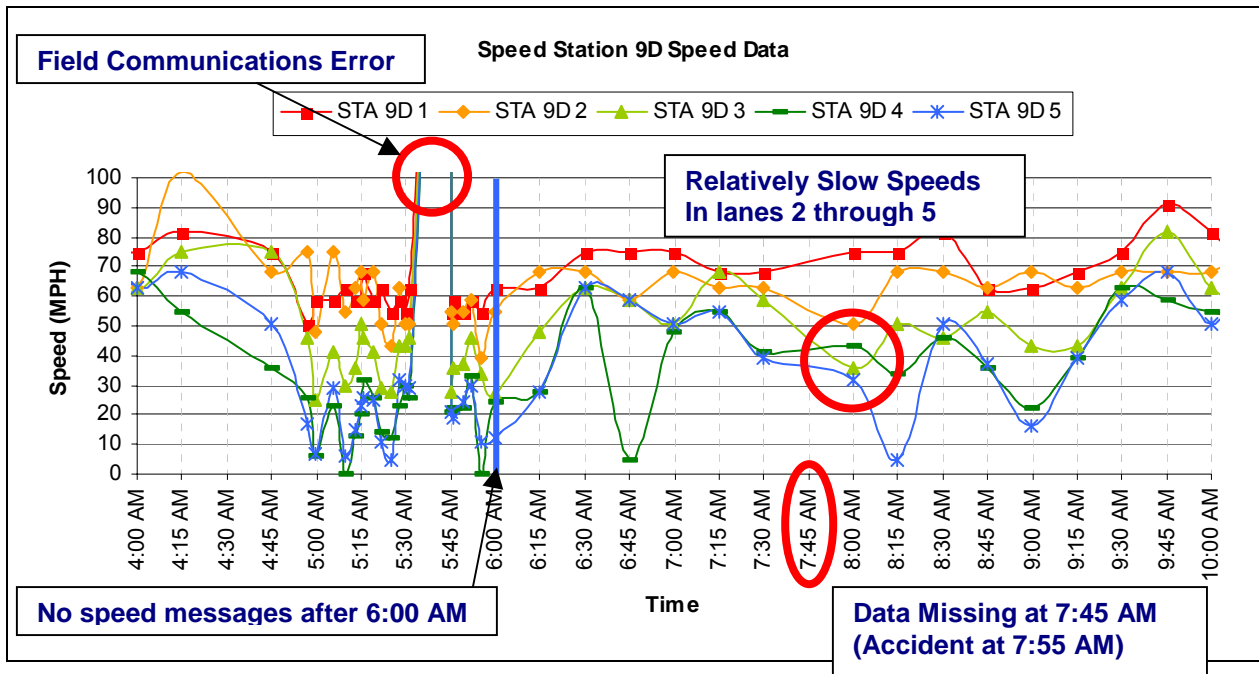

Figure 3.3.3.2. Speed Site 9D Speed Data.

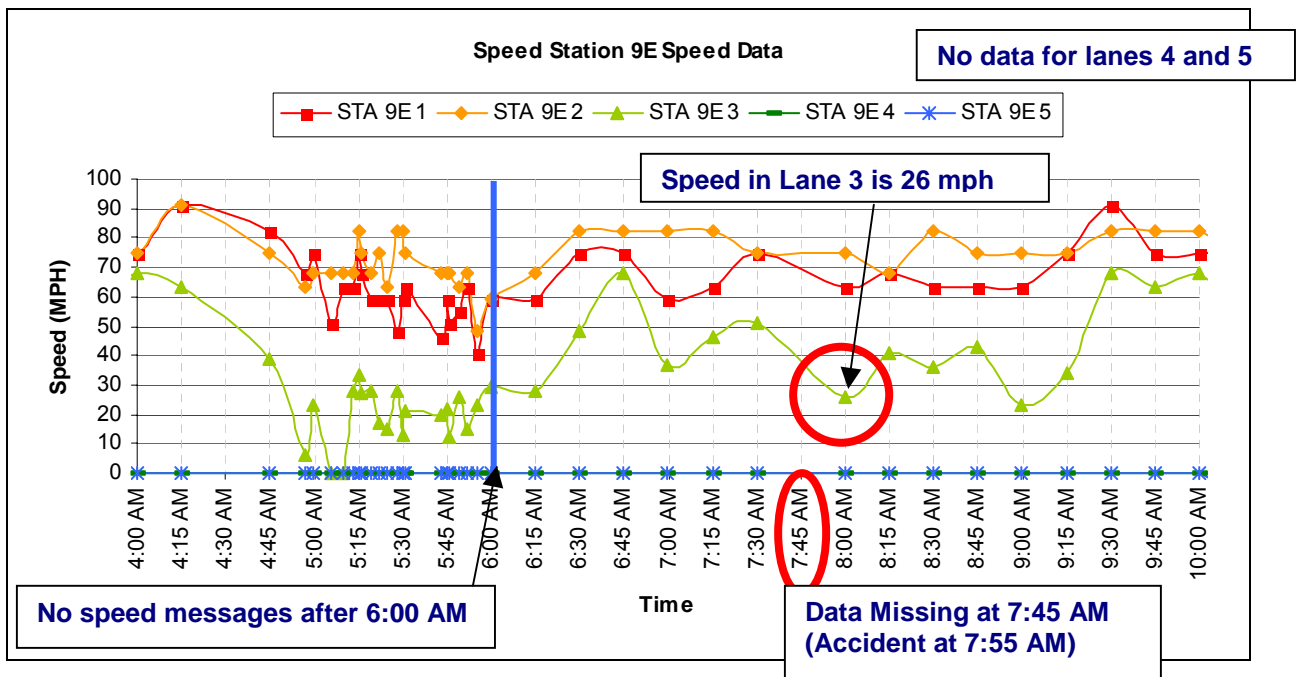

Figure 3.3.3.3. Speed Site 9E Speed Data.

3.3.3.2 January 12, 2004

An accident occurred at 6:05 am involving four vehicles in stop-and-go traffic. All four vehicles were in lane 4 traveling on southbound I-5 at milepost 13.72, which is south of the 'Y' merge and 0.2 miles south of Stewart Road. Two people were injured. The roadway was wet and the accident occurred at dawn. The reporting CHP officer noted the visibility as 1500 feet in the accident report and classified the accident as a rear-end collision. The vehicle at fault was a 1999 Ford F-450 truck which collided with the car in front of it. The subsequent collision set off a forward chain reaction resulting in two additional collisions. A digitized image of the CHP officer's sketch is included in Figure 3.3.3.4.

The CAWS activated several times for fog-visibility at Level 1 (ADVISE 45 MPH) prior to this event (before 4:05 am), but the fog was not severe enough to trigger a Level 2 visibility warning flag. This means that visibility remained above 200 feet at all of the weather stations. From 4:05 am until the time of the accident at 6:05 am, visibility at all sites was above any alarm levels and no messages were displayed on the CMSs.

The first speed event recorded in the TMS log file occurred at 6:55 am. This was the first time during that day when logging occurred more frequently than every 15 minutes. The first Signview message for speed was sent at 6:29 am.

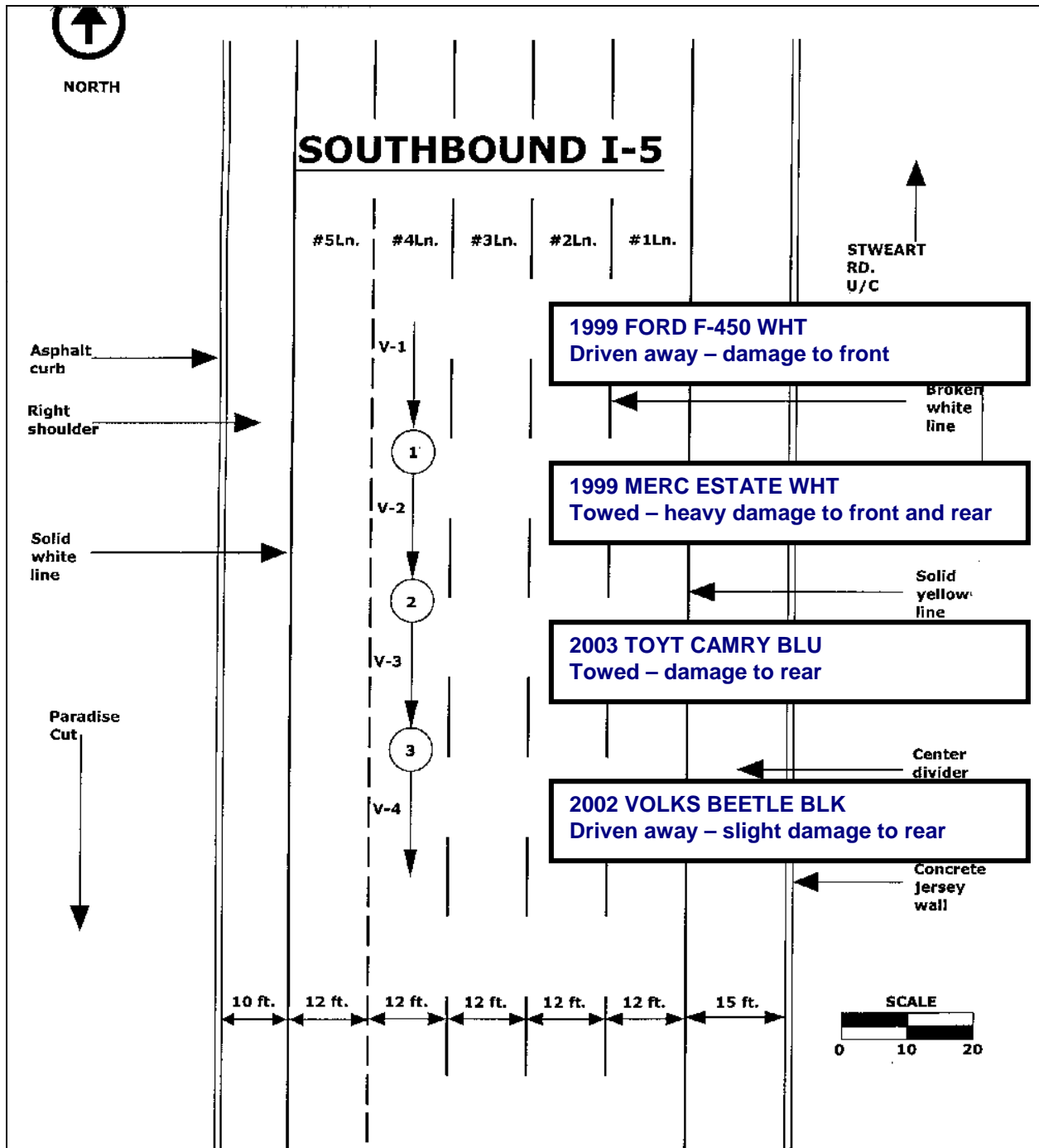

Figure 3.3.3.4. CHP Accident Site Sketch.

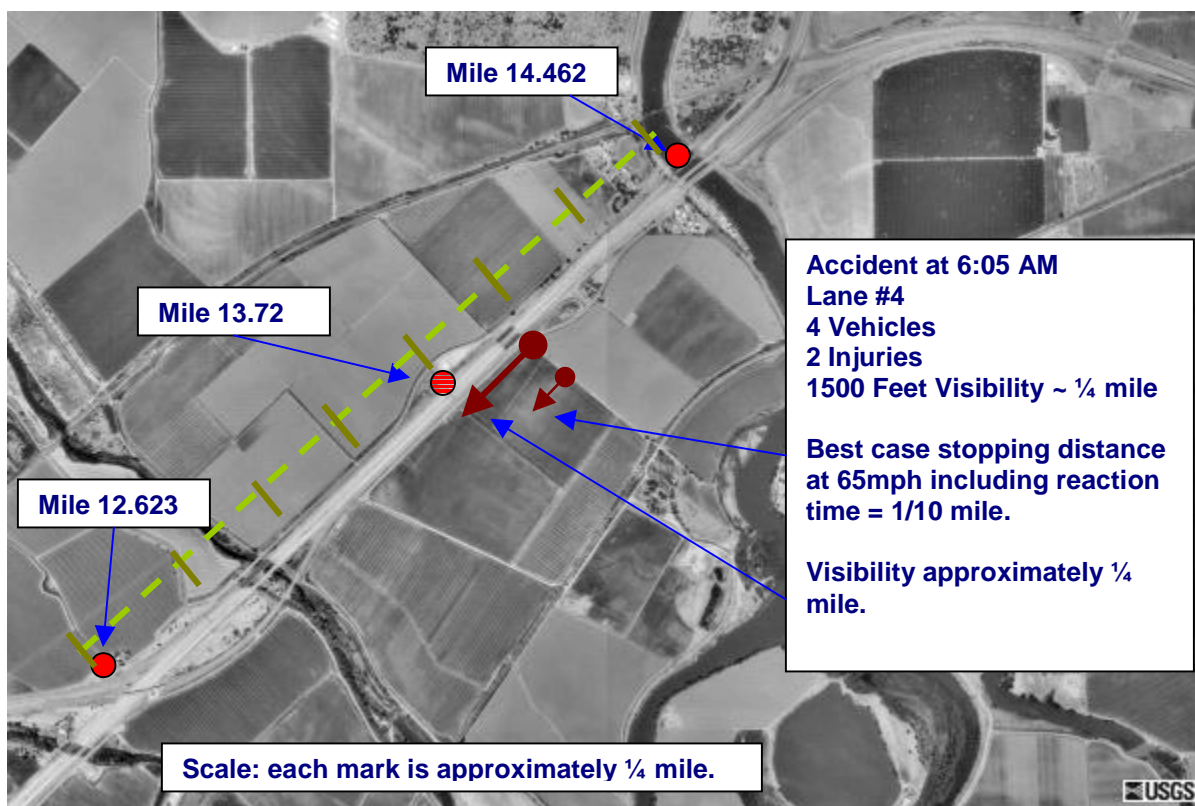

Figure 3.3.3.5. Accident Location (2004-01-12).

Weather Station 9, the closest to the accident, reported visibility as 324 meters (1063 feet); the other CMSs showed similar readings. The worst visibility was reported at Weather Station 1 (Mathew’s Road) and was 890 feet. The QCMS communications log entries for all Weather Stations at 6:00 am are shown below. The logging interval for the QCMS was 5 minutes. The M M M fields in the entry for Weather Station 9 indicate “Missing Data” at the reporting time.

```
01 04-01-12 06:00:00 00 271.5 2.0 090 11.2 8.2 82 1017.4 0.000 0.000
02 04-01-12 06:00:00 00 298.7 1.7 077 8.6 8.2 97 1041.9 0.000 0.000
03 04-01-12 06:00:01 00 314.4 1.2 133 8.9 8.1 95 1016.9 0.000 0.000
04 04-01-12 06:00:01 00 315.1 2.6 130 9.6 9.6 100 1014.0 0.000 0.000
05 04-01-12 06:00:02 00 347.7 2.3 090 9.6 7.8 89 1041.7 0.000 0.000
06 04-01-12 06:00:02 00 286.8 1.5 129 8.3 8.3 100 1015.1 0.000 0.000
07 04-01-12 06:00:03 00 327.4 1.8 085 8.3 7.6 95 1013.4 0.000 0.000
08 04-01-12 06:00:03 00 307.8 3.0 085 8.5 7.9 96 1017.5 0.000 0.000
09 04-01-12 06:00:04 00 324.0 2.2 061 M M M 1014.0 0.000 0.000
```

In this case, the CAWS functioned as designed, and its handling of missing data from WS 9 was confirmed. The other (correctly functioning) weather stations properly did not generate warning messages when visibilities did not warrant it. Although visibility was somewhat poor, the accident could best be attributed to driver error compounded by lane speed differences in the merge zone.

3.3.3.3 January 1–13, 2004

From before 1-1-04 to 1-13-04 13:35 there was a relative humidity sensor failure for Weather Station 9. Since the detection of fog requires a properly functioning RH sensor in addition to visibility, there could be no visibility activations due to the set-up of the CMS system. District staff were not aware of the dependency of the fog reading on this sensor, so its repair was not necessarily considered an urgent priority. As will be discussed in greater detail later, with a non-functioning relative humidity sensor the only ‘master computer data byte alarm’ (MCDB) codes sent by the QCMS computer to Signview are for visibility alone, which will not cause activation of a CMS. Consequently, during this period of peak fog, CMS 9 could not activate a fog warning. The two acute situations in which the CMS should have displayed a warning message but did not are described below.

On 1-8-04 [23:00-0:55]:

Table 3.3.3.1. Weather Log (1-8-04).

SITE 9										
Time	MC DB	Vis [m]	Wind [m/s]	Wind Dir [deg]	Wet Temp [C]	Dry Temp [C]	Rel Hum [%]	Bar Press [KPa]	Rain Vol [inch]	Rain Rate [inch/h]
23:00	0	211.3	2.2	276	M	M	M	1013.4	0.01	0
23:05	5	127.3	2.3	274	M	M	M	1013.4	0.01	0
23:10	5	98.7	2.3	266	M	M	M	1013.4	0.01	0
23:15	5	88.1	2.7	262	M	M	M	1013.4	0.01	0
23:20	5	76	2.6	262	M	M	M	1013.4	0.01	0
23:25	5	84.9	1.9	273	M	M	M	1013.3	0.01	0
23:30	5	88.4	2	269	M	M	M	1013.3	0.01	0
23:35	5	89.6	2	270	M	M	M	1013.2	0.01	0
23:40	5	83.5	1.8	269	M	M	M	1013.2	0.01	0
23:45	5	80.3	1.9	272	M	M	M	1013.2	0.01	0
23:50	5	71.1	1.9	276	M	M	M	1013	0.01	0
23:55	5	64.5	1.9	285	M	M	M	1013	0.01	0
0:00	5	61.6	2.1	280	M	M	M	1013.2	0.01	0
0:05	5	66.4	2.2	280	M	M	M	1013.2	0	0
0:10	5	66.2	2.6	278	M	M	M	1013.2	0	0
0:15	5	68.9	2.8	278	M	M	M	1013.2	0	0
0:20	5	75.8	2.2	280	M	M	M	1013.2	0	0
0:25	5	82.9	1.8	274	M	M	M	1013.2	0	0
0:30	5	93.4	1.8	287	M	M	M	1013.2	0	0
0:35	5	123	1.7	291	M	M	M	1013.2	0	0
0:40	0	158.2	2	272	M	M	M	1013.2	0	0
0:45	5	148.1	1.9	270	M	M	M	1013.2	0	0
0:50	5	145.3	1.6	277	M	M	M	1013.2	0	0
0:55	0	161.5	2	273	M	M	M	1013.1	0	0

On 1-11-04 [7:10-9:00]:

Table 3.3.3.2. Weather Log (1-11-04).

SITE 9										
Time	MC DB	Vis [m]	Wind [m/s]	Wind Dir [deg]	Wet Temp [C]	Dry Temp [C]	Rel Hum [%]	Bar Press [KPa]	Rain Vol [inch]	Rain Rate [inch/h]
7:10	5	138.5	1.4	81	M	M	M	1011.4	0	0
7:15	5	98.7	1.2	78	M	M	M	1011.5	0	0
7:20	5	85.2	1	94	M	M	M	1011.4	0	0
7:25	5	89.8	0.8	100	M	M	M	1011.4	0	0
7:30	5	100.3	1.1	108	M	M	M	1011.4	0	0
7:35	5	89.6	0.8	109	M	M	M	1011.4	0	0
7:40	5	88.4	0.8	141	M	M	M	1011.4	0	0
7:45	5	77.7	1	158	M	M	M	1011.5	0	0
7:50	5	70.4	1.2	143	M	M	M	1011.4	0	0
7:55	5	65.6	1.2	151	M	M	M	1011.4	0	0
8:00	6	60.3	1.3	159	M	M	M	1011.5	0	0
8:05	6	56.8	1.5	166	M	M	M	1011.5	0	0
8:10	6	48	1.5	157	M	M	M	1011.5	0	0
8:15	6	48.9	1.4	152	M	M	M	1011.5	0	0
8:20	6	50.7	1.4	149	M	M	M	1011.5	0	0
8:25	6	50.3	1.3	151	M	M	M	1011.5	0	0
8:30	6	51.9	1.3	161	M	M	M	1011.5	0	0
8:35	6	60.6	1.4	151	M	M	M	1011.7	0	0
8:40	5	78.3	1.3	125	M	M	M	1011.7	0	0
8:45	5	96.3	1.3	130	M	M	M	1011.7	0	0
8:50	5	128.7	1.5	120	M	M	M	1011.7	0	0
8:55	5	152.3	1.7	129	M	M	M	1011.7	0	0
9:00	5	142.6	1.9	116	M	M	M	1011.7	0	0

3.3.3.4 February 2 – March 19, 2005

The visibility sensor for Weather Station 2 was inoperative from 2-02-05 through 3-19-05. During this period the data logged for visibility was 'M', but at inconsistent times a '0' visibility distance was logged. This should have intermittently caused the activation of a dense fog warning on CMS 2. However, since the weather server depends on the relative humidity (RH) sensor, and RH was low at the time, only a non-fog visibility alarm code was sent to Signview, which did not cause a warning message to be generated.

3.3.3.5 January 2, 2004

On 1-2-04 from 3:40 am to 7:25 am the QCMS computer kept the same flag active for each site because of a communication problem between the weather computer and weather stations. In the event of a communications loss between the QCMS and the field computers, alarm codes sent to the Signview computer are left at their existing state rather than reverting to zero or some code for 'unknown'. In this case, only three of the weather sites actually maintained the same alarm level.

In Table 3.3.3.4 below, the cause of a double entry at 7:25 am was a system was re-initialization '7:25:34 AM SYSTEM INIT' which brought the system out of its communication error. But the system went back into an error state one minute later. The log has a gap between 7:28 am and 8:33 am where the system did not log until it was initialized again '8:33:28 AM SYSTEM INIT'. The system starts logging normally after that point. This is reflected in the Signview log data of Table 3.3.3.3 where CMS 1 receives a blank message after holding the 'DENSE FOG/ADVISE 45MPH' during the communication errors. (Weather logs for this date are seven minutes ahead of the CAWS-evaluation clock).

Table 3.3.3.3. CAWS-evaluation CMS 1 Messages.

Time	Text
1/2/2004 3:24	BLANK MESSAGE
1/2/2004 3:27	DENSE FOG/ADVISE 30MPH
1/2/2004 7:18	BLANK MESSAGE
1/2/2004 8:27	DENSE FOG/ADVISE 45MPH
1/2/2004 8:39	BLANK MESSAGE

Table 3.3.3.4. Weather Log (1-2-04).

Time	Site								
	1	2	3	4	5	6	7	8	9
	MC DB								
3:30:00	2	3	3	2	1	1	1	3	5
3:35:00	2	3	3	2	1	1	1	3	5
3:40:00	2	3	3	2	1	1	1	3	5
3:45:00	2	3	3	2	1	1	1	3	5
3:50:00	2	3	3	2	1	1	1	3	5
3:55:00	2	3	3	2	1	1	1	3	5
4:00:00	2	3	3	2	1	1	1	3	5
4:05:00	2	3	3	2	1	1	1	3	5
4:10:00	2	3	3	2	1	1	1	3	5
4:15:00	2	3	3	2	1	1	1	3	5
4:20:00	2	3	3	2	1	1	1	3	5
4:25:00	2	3	3	2	1	1	1	3	5
4:30:00	2	3	3	2	1	1	1	3	5
4:35:00	2	3	3	2	1	1	1	3	5
4:40:00	2	3	3	2	1	1	1	3	5
4:45:00	2	3	3	2	1	1	1	3	5
4:50:00	2	3	3	2	1	1	1	3	5
4:55:00	2	3	3	2	1	1	1	3	5
5:00:00	2	3	3	2	1	1	1	3	5
5:05:00	2	3	3	2	1	1	1	3	5
5:10:00	2	3	3	2	1	1	1	3	5
5:15:00	2	3	3	2	1	1	1	3	5
5:20:00	2	3	3	2	1	1	1	3	5
5:25:00	2	3	3	2	1	1	1	3	5
5:30:00	2	3	3	2	1	1	1	3	5
5:35:00	2	3	3	2	1	1	1	3	5
5:40:00	2	3	3	2	1	1	1	3	5
5:45:00	2	3	3	2	1	1	1	3	5
5:50:00	2	3	3	2	1	1	1	3	5
5:55:00	2	3	3	2	1	1	1	3	5
6:00:00	2	3	3	2	1	1	1	3	5
6:05:00	2	3	3	2	1	1	1	3	5
6:10:00	2	3	3	2	1	1	1	3	5
6:15:00	2	3	3	2	1	1	1	3	5
6:20:00	2	3	3	2	1	1	1	3	5
6:25:00	2	3	3	2	1	1	1	3	5

6:30:00	2	3	3	2	1	1	1	3	5
6:35:00	2	3	3	2	1	1	1	3	5
6:40:00	2	3	3	2	1	1	1	3	5
6:45:00	2	3	3	2	1	1	1	3	5
6:50:00	2	3	3	2	1	1	1	3	5
6:55:00	2	3	3	2	1	1	1	3	5
7:00:00	2	3	3	2	1	1	1	3	5
7:05:00	2	3	3	2	1	1	1	3	5
7:10:00	2	3	3	2	1	1	1	3	5
7:15:00	2	3	3	2	1	1	1	3	5
7:20:00	2	3	3	2	1	1	1	3	5
7:25:00	0	0	0	0	0	0	0	0	0
7:25:00	0	0	0	0	0	0	0	0	0
8:35:00	1	1	0	0	0	0	0	1	0
8:40:00	1	1	0	0	0	0	0	1	0

3.3.3.6 January 19, 2004 and January 30, 2004

The QCMS system weather log file excerpts in Table 3.3.3.5 and

Table 3.3.3.6 indicates an alarm code (MC DB) of 1 sent to the Signview computer, resulting in no fog activation despite dense fog at this location. Alarm code of 1 resulted from a communications error with these two field sites.

Table 3.3.3.5. Weather Log (1-19-04).

SITE 9										
Time	MC DB	Vis [m]	Wind [m/s]	Wind Dir [deg]	Wet Temp [C]	Dry Temp [C]	Rel Hum [%]	Bar Press [KPa]	Rain Vol [inch]	Rain Rate [inch/h]
1:10	1	127.5	1.4	80	4.1	3.5	96	1015.7	0	0
1:15	1	95.2	1.5	78	3.8	3	95	1015.7	0	0
1:20	1	131.4	1.3	80	3.7	3.1	96	1015.7	0	0

Table 3.3.3.6. Weather Log (1-19-04).

SITE 8										
Time	MC DB	Vis [m]	Wind [m/s]	Wind Dir [deg]	Wet Temp [C]	Dry Temp [C]	Rel Hum [%]	Bar Press [KPa]	Rain Vol [inch]	Rain Rate [inch/h]
2:05:00	1	125.5	0.4	192	4.2	3	92	1028.4	0	0
2:10:00	1	101.9	1	202	4	2.8	92	1028.5	0	0

A similar situation occurred on January 30, 2004, apparent from the log file data shown in Table 3.3.3.7. The time values listed in the Weather log of Table 3.3.3.7 are 15 minutes ahead of Signview log times listed in Table 3.3.3.8.

Table 3.3.3.7. Weather Log (1-30-04).

Time	SITE 2									
	MC DB	Vis [m]	Wind [m/s]	Wind Dir [deg]	Wet Temp [C]	Dry Temp [C]	Rel Hum [%]	Bar Press [KPa]	Rain Vol [inch]	Rain Rate [inch/h]
4:20:00	2	58.9	1.5	186	6.8	5.9	94	1042.8	0	0
4:25:00	2	46.4	1.2	197	6.5	5.5	94	1042.9	0	0
4:30:00	1	101.9	1	183	6.4	5.5	94	1042.8	0	0

Table 3.3.3.8. Signview Log.

Date	Time	CMS	Message
1/30/2004	4:07	2	DENSE FOG/ADVISE 45mph
1/30/2004	4:10	2	DENSE FOG/ADVISE 30mph
1/30/2004	4:19	2	DENSE FOG/ADVISE 45mph
1/30/2004	5:16	2	DENSE FOG/ADVISE 45mph

3.3.4 Weather System Communications-related Problems, Various Dates

The following are examples highlight revealed the existence of communication errors between the weather stations and QCMS weather server. These are included to show how extended down periods of some sites could cause public distrust in system because of the lack of message activation when there should have been. Since weather logs only report 'M' for any data that it does not receive there is no definite explanation for the significant amounts of missing data. Possible reasons could include communication failure between weather stations and the weather server or power loss to the weather stations themselves.

- Weather station 2 from 4-7-04 8:50 to 4-26-04 13:05. During this period there was a wind event for weather stations 3 and 4 on 4-24-04 [16:00 – 18:30]. Because of the proximity of these sites to weather station 2, there most likely was a wind event for weather site 2.
- All weather stations from 7-27-04 23:35 to 7-29-04 8:15
- Weather stations from 7-29-04 8:35 to 8-4-04 13:05. There was a 10-minute period where data was received on 7-29-94 8:15 that directly followed the all weather site error 7-27-04 23:35 to 7-29-94 8:15. Communications were once again lost soon after the 10-minute period.
- Weather station 3 from 8-7-04 1:15 to 8-9-04 9:55. Immediately following the error there was a wind event but there is no way of knowing when the wind event actually started. Supporting data for this incident is shown in Table 3.3.4.1 and Table 3.3.4.2.

Table 3.3.4.1. QCMS Weather Log, 8-9-04.

Time	SITE 3									
	MC DB	Vis [m]	Wind [m/s]	Wind Dir [deg]	Wet Temp [C]	Dry Temp [C]	Rel Hum [%]	Bar Press [KPa]	Rain Vol [inch]	Rain Rate [inch/h]
9:45:00	0	M	M	M	M	M	M	M	M	M
9:50:00	0	M	M	M	M	M	M	M	M	M
9:55:00	0	M	M	M	M	M	M	M	M	M
10:00:00	8	30338	15.6	228	21.3	15.8	73	675.5	0	0
10:05:00	0	28677	3.6	310	23.6	15	59	1013.3	0	0

Table 3.3.4.2. Signview Log.

Date	Time	CMS	Message
8/9/2004	10:09	3	GUSTY WIND WARNING

- All weather stations from 9-15-04 1:00 pm to 9-16-04 1:55 pm. Examining the CAWS-evaluation data indicates that there were no visibility activations generated by weather station 1 which leads to the assumption that there was a communication error during this time.
- Weather station 7 from 9-23-04 11:20 to 10-01-04 2:20 but communication problems started again on 10-01-04 8:40 to 11-03-04 14:45.
- All weather stations from 10-30-04 17:45 to 11-03-04 14:45. Examining the CAWS-evaluation data indicates that there was one visibility event missed. Figure 3.3.4.1 shows the D10 Analyzer output for this time period.

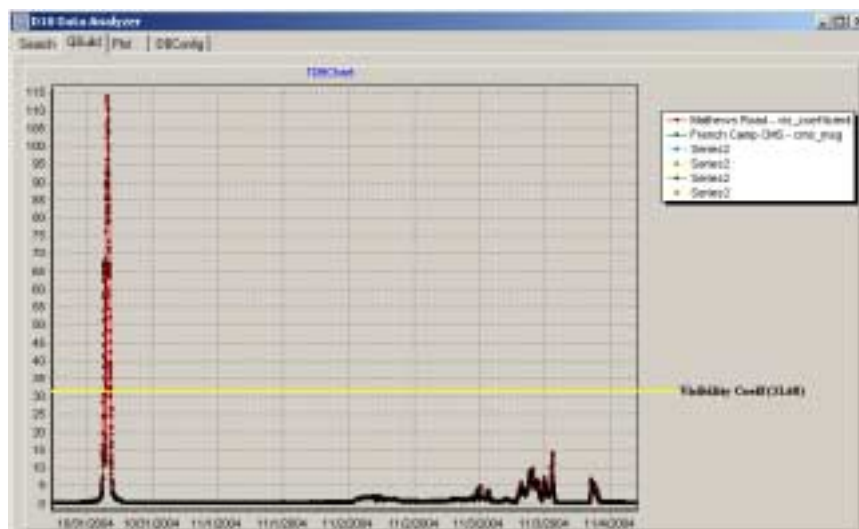

Figure 3.3.4.1. D10 Analyzer Screenshot

- Weather Station 7 from 11-07-04 6:35 to 11-21-04 21:35.
- All weather stations from 11-07-04 6:35 am to 11-10-04 10:05 am. Due to a communications failure, fog level flags of 2 and 3 were being sent to the Signview computer for weather stations 2, 3, 7 and 8. These flags were sent until 11-08-04 12:46:54 pm when a 'SYSTEM INIT' was sent which reset all flags to 0. Examining the CAWS-evaluation data indicates that two fog events were missed on 11-07-04. Figure 3.3.4.2 shows the D10 Analyzer output for this time period.



Figure 3.3.4.2. D10 Analyzer Screenshot, showing graphical depiction of fog over the course of an activation event, 11-07-04.

- Weather station 7 from 11-25-04 9:15 to 11-28-04 18:40.
- Weather station 7 from 12-01-04 9:30 to 2-02-05 10:05.
- All weather stations from 1-26-05 7:20 pm to 2-02-05 10:05 am. CAWS-evaluation data system data from this site (at Mathews Road) indicated that there should have been three visibility activations. Figure 3.3.4.3 shows a graphical depiction of the visibility levels for this time period. Dense fog periods are indicated by the peaks in the plot of the extinction coefficient from the visibility sensor at this station.

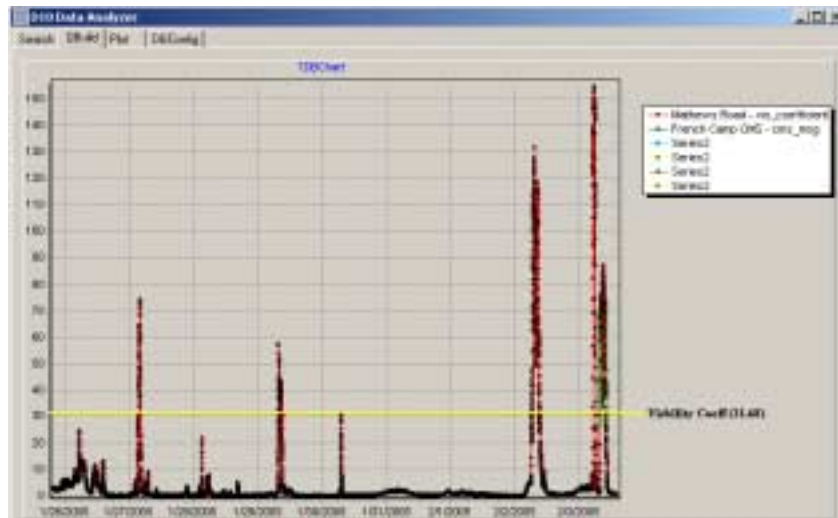

Figure 3.3.4.3. Visibility at WS 1, 9-day profile starting 1-26-05, from D10 Analyzer.

- Body Weather station 2 from 1-26-05 7:20 pm to later then 3-22-05 11:55 pm (Logs were only available through 3-22-05).
- All weather stations from 2-17-05 11:05 pm to 2-23-05 8:25 am. CAWS-evaluation system visibility data is shown in Figure 3.3.4.4 indicating the missed fog activation.

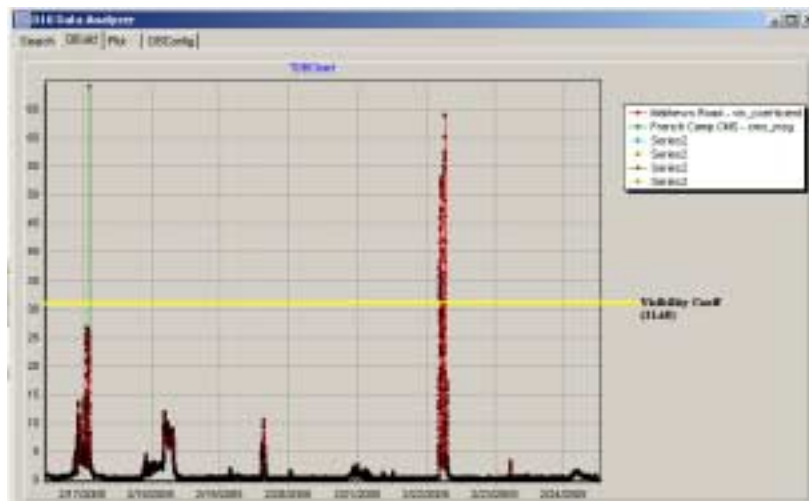

Figure 3.3.4.4. D10 Analyzer Screenshot, 2-17-05 through 2-24-05.

- All weather stations from 3-05-05 4:05 am to 3-0-05 8:55 am. CAWS-evaluation data represented in Figure 3.3.4.5 shows two missed fog activations.

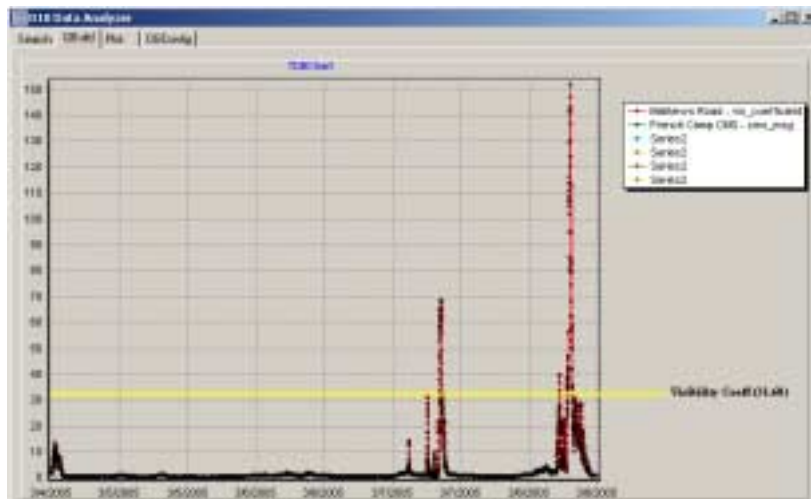

Figure 3.3.4.5. D10 Analyzer Screenshot.

- Weather station 7 from 3-14-05 9:15am to later than 3-22-05 11:55 pm.
- All weather stations from 3-19-05 4:25am to 3-22-05 11:55 pm.

3.3.5 Manual Warning Events – Problems with Automatic Override

The CAWS is part of the statewide Amber Alert system, intended to display messages to drivers instructing them to look out for particular vehicles. Table 3.3.5.1 lists all amber alert messages show on CMS #1 during the operation of the CAWS-evaluation system, as recorded by the CAWS evaluation data acquisition system. Amber alert messages are manually entered by TMC personnel.

In general, a manual message is a text message not automatically generated and displayed by the Signview computer. TMC staff have the ability to display manual messages by entry on the Signview computer console. Manual messages may be entered at any time, and appear asynchronously. However, the logic implemented by the Signview computer immediately overrides manual messages with automatically generated ones. Also, manual messages are not restored after the automated override is past. The following cases demonstrate cases in which this unexpected behavior occurred.

Table 3.3.5.1. Amber Alert messages placed on CMS 1, Aug. 2002 – March 2005.

Amber Alert Messages		
id	Description	Date Displayed
37	AMBER ALERT 1-800-TELL-CHP/WHI FORD BRONC LIC - 1AIZ962	August 1, 2002
38	AMBER ALERT 1-800-TELL-CHP/WHI FORD BRONCO LIC - 1AIZ962	August 1, 2002
39	CHILD ABDUCTION 1-800-TELL-CHP/WHI FORD BRONC LIC - 1AIZ962	August 1, 2002
40	CHILD ABDUCTION 1-800-TELL-CHP/WHITE FORD BRONCO LIC - 1AIZ962	August 1, 2002
41	CHILD ABDUCTION 1-800-TELL-CHP/OLDER LT BLUE HONDA ACCORD LIC - 4?????	August 3, 2002
42	POSS. ABDUCTION LA PD 213-485-4061/JESSICA CORTEZ 4YRS, BLACK HAIR BROWN E	August 12, 2002
43	ABDUCTION 10 YEAR GIRL-1982 DODGE TRUCK BLUE/WHITE LIC#4L50054 RIVERSIDE P	August 20, 2002
44	ABDUCTION DRK BLUE HYUNDAI 2 DR 4SHV526/661-327-711 DRK BLUE HYUNDAI 2 DR	August 30, 2002
56	CHILD ABDUCTION 95 DODGE DAKOTA INDIANA PLATES/229929A OR 406211A 1-800-TE	March 6, 2003
57	CHILD ABDUCTION 95 WHITE DODGE DAKOTA/INDIANA PLATES 229929A OR 406211A	March 6, 2003
63	CHILD ABDUCTION 98 SATURN 4DR CA LIC 4AUA591/[REPEATED]	August 20, 2003
64	CHILD ABDUCTION GRN HONDA CIVIC CA LIC 4MFP204/[REPEATED]	August 30, 2003
70	AMBER ALERT WHT PLYM VOYAGER CA LIC 4DYR509/[REPEATED]	November 11, 2003
71	AMBER ALERT WHT 01 CARAVAN CA LIC 4SEV029/[REPEATED]	November 11, 2003
73	CHILD ABDUCTION CHEVY BLZR GREEN CA LIC 3AMP149/1-800-TELL CHP REP	April 30, 2004
75	CHILD ABDUCTION 95 BLU LANDROVER LIC CA 4AHC255/BLANK	August 9, 2004
77	AMBER ALERT 1991 TAN CAMRY CA LIC# 3KVV243	December 21, 2004
78	CHILD ABDUCTION 1991 FORD TEMPO CA LIC# 4ZLE067/[REPEATED]	January 17, 2005
79	CHILD ABDUCTION MAROON HONDA ACC BROKEN RT WINDOW	March 3, 2005

3.3.5.1 August 9, 2004

At 9:33 am, a manual “Amber Alert” message was placed on all CMSs. The Signview log, shown in Table 3.3.5.2, indicates that “CHILD ABDUCTION 95 BLU LANDROVER LIC CA 4AHC255” was flashed on the CMSs. An excerpt from the The CAWS-evaluation database, shown in Table 3.3.5.3, indicates that this manual message was activated for 4 hours 12 minutes on CMS 1. The weather log data of

Table 3.3.5.4 indicates the presence of high winds at 9:56 am. Table 3.3.5.2 shows that at 9:56 am a high wind warning message ‘GUSTY WIND WARNING’ was sent to CMS 3 that overwrote the manual message. The wind warning message duration was only 5 minutes (one weather system polling cycle). The manual message was never resent to CMS 3. However, the Amber Alert message was not restored on CMS 3 due to the Signview logic. Drivers traveling south on I-5 would observe a blank message on CMS 3, while all other CMSs displayed the Amber Alert message. The log times in Table 3.3.5.2 and

Table 3.3.5.4 have been aligned to the CAWS-evaluation database (absolute) time.

Table 3.3.5.2. Signview Message Log.

Date	Time	CMS	Message
8/9/2004	9:33	1	CHILD ABDUCTION 95 BLU LANDROVER LIC CA 4AHC255/
8/9/2004	9:34	2	CHILD ABDUCTION 95 BLU LANDROVER LIC CA 4AHC255
8/9/2004	9:36	3	CHILD ABDUCTION 95 BLU LANDROVER LIC CA 4AHC255
8/9/2004	9:37	4	CHILD ABDUCTION 95 BLU LANDROVER LIC CA 4AHC255
8/9/2004	9:38	5	CHILD ABDUCTION 95 BLU LANDROVER LIC CA 4AHC255
8/9/2004	9:39	6	CHILD ABDUCTION 95 BLU LANDROVER LIC CA 4AHC255
8/9/2004	9:40	7	CHILD ABDUCTION 95 BLU LANDROVER LIC CA 4AHC255
8/9/2004	9:41	8	CHILD ABDUCTION 95 BLU LANDROVER LIC CA 4AHC255
8/9/2004	9:44	9	CHILD ABDUCTION 95 BLU LANDROVER LIC CA 4AHC255
8/9/2004	9:56	3	GUSTY WIND WARNING

Table 3.3.5.3. CAWS-evaluation database entries.

Date	Time	Text
8/9/2004	9:33	CHILD ABDUCTION 95 BLU LANDROVER LIC CA 4AHC255/BLANK
8/9/2004	13:45	BLANK MESSAGE

Table 3.3.5.4. Weather Log (8-9-04)

Time	SITE 3									
	MC DB	Vis [m]	Wind [m/s]	Wind Dir [deg]	Wet Temp [C]	Dry Temp [C]	Rel Hum [%]	Bar Press [KPa]	Rain Vol [inch]	Rain Rate [inch/h]
9:41:00	0	M	M	M	M	M	M	M	M	M
9:46:00	0	M	M	M	M	M	M	M	M	M
9:51:00	0	M	M	M	M	M	M	M	M	M
9:56:00	8	30338	15.6	228	21.3	15.8	73	675.5	0	0
10:01:00	0	28677	3.6	310	23.6	15	59	1013.3	0	0

3.3.5.2 October 10, 2004

A wind warning activation of CMS 5 started at 9:30 am. As shown in the Signview log excerpted in Table 3.3.5.5, a manual message was sent at 11:41 am to CMS 5 and CMS 9: "I5 CLOSED AT 132/DUE TO ACCIDENT". According to the Signview log, this message was displayed on CMS 9 for 4 hours and 17 minutes. At CMS 5, however, the manual message was over-written by the wind warning message four minutes after the manual message was sent to the CMS, and the manual message was never redisplayed after the wind event was concluded one minute later. (Signview log and weather log times are aligned for and Table 3.3.5.5 and Table 3.3.5.6).

Table 3.3.5.5. Signview Log.

Date	Time	CMS	Message
10/19/2004	9:30	5	GUSTY WIND WARNING
10/19/2004	9:45	5	GUSTY WIND WARNING
10/19/2004	10:21	5	GUSTY WIND WARNING
10/19/2004	11:21	5	GUSTY WIND WARNING
10/19/2004	11:41	5	I5 CLOSED AT 132/DUE TO ACCIDENT
10/19/2004	11:45	5	GUSTY WIND WARNING

Table 3.3.5.6. Weather Log for Site 5 (10-19-04).

Time	SITE 5									
	MC DB	Vis [m]	Wind [m/s]	Wind Dir [deg]	Wet Temp [C]	Dry Temp [C]	Rel Hum [%]	Bar Press [KPa]	Rain Vol [inch]	Rain Rate [inch/h]
9:25:00	0	218.8	8.4	65	14.8	10.7	77	1005.5	2.724	0.72
9:30:00	8	237.7	11.4	62	14.7	10.7	77	1004.7	2.844	3.12
9:35:00	8	291.4	12.5	61	14.6	10.6	77	1004.4	3.034	0.24
9:40:00	0	268.4	10.7	63	14.7	10.7	77	1004.6	3.224	4.32
9:45:00	8	230.3	11.2	60	14.6	10.8	78	1004.4	3.49	2.34
9:50:00	8	214.9	12.5	61	14.7	10.9	78	1003.9	3.642	2.64
9:55:00	8	211.1	12.5	60	14.6	10.8	78	1003.8	3.894	3.48
10:00:00	8	241.6	11.8	62	14.7	10.9	78	1004.1	4.094	2.04
10:05:00	8	294.5	12.8	60	14.9	10.9	77	1004.2	4.114	0.24
10:10:00	8	1452	11.8	63	14.7	10.9	78	1004.2	4.13	0
10:15:00	0	1726.3	10.8	65	14.7	11	79	1004.4	4.142	0.24
10:20:00	8	1200.9	12.1	61	14.6	11	79	1004.3	4.176	0.72
10:25:00	8	1051.3	12.7	59	14.5	10.8	79	1004.2	4.212	0.24
10:30:00	8	1027	12.8	58	14.6	10.9	79	1004.2	4.23	0.12
10:35:00	8	1772.6	12.7	62	14.7	11.1	79	1004.3	4.25	0.36
10:40:00	8	2886.2	13.7	61	14.7	11.1	79	1004.4	4.26	0.12
10:45:00	8	5787.6	12.3	62	14.8	11.2	79	1004.6	4.26	0
10:50:00	8	5445.7	12.5	63	14.8	11.2	79	1004.6	4.26	0
10:55:00	8	4280.4	11.4	66	14.8	11.3	80	1004.9	4.262	0.12
11:00:00	8	2095	12.8	65	15	11.4	79	1005.1	4.326	0.4
11:05:00	8	1570.7	13	66	14.9	11.2	79	1005	4.374	0.48
11:10:00	8	1664.6	12.8	68	15	11.2	78	1005	4.434	0.84
11:15:00	0	1269.5	11	68	14.9	11.1	78	1005	4.46	0
11:20:00	8	2095.9	11.7	70	14.9	11.2	79	1005.2	4.47	0.36
11:25:00	8	3189.6	13.2	69	15	11.2	79	1005.2	4.53	0.72
11:30:00	8	2194.2	13	69	15.3	11.3	77	1005	4.658	1.08
11:35:00	0	2002.4	10.8	71	15.2	11.1	77	1005	4.706	0.24
11:40:00	0	1286.8	10.6	70	15.4	11.1	76	1005	4.72	0.12
11:45:00	8	691.1	11.8	70	15.3	11	76	1004.9	4.728	0.06
11:50:00	8	831.7	11.9	75	15.1	10.9	76	1004.8	4.76	0.36
11:55:00	8	1054.6	11.7	71	15	10.8	76	1004.8	4.778	0.36
12:00:00	8	578	12.1	68	14.9	10.8	77	1004.7	4.858	1.44
12:05:00	8	431	12.2	72	14.8	10.8	77	1004.7	5.018	1.8
12:10:00	0	307.3	10.4	70	14.7	10.7	77	1004.8	5.092	1.08

3.3.5.3 December 12, 2004

Shortly after the manual message “HIGHWAY ADVISORY AHEAD/ACCIDENT AT MOSSDALE RD LANES BLOCKED” was displayed on CMS 2 and CMS 5, a speed event occurred at both sites that resulted in the overwriting of the manual message. Since the manual message was overwritten at both sites, it is unknown how long the message was intended to be displayed. The Speed log time data of Table 3.3.5.8 was originally six minutes slower than the Signview log time data of Table 3.3.5.7. It has been re-aligned to the Signview time.

Table 3.3.5.7. Signview log entries.

Date	Time	CMS	Message
12/15/2004	12:03	2	HIGHWAY ADVISORY AHEAD / ACCIDENT AT MOSSDALE RD LANES BLOCKED
12/15/2004	12:12	2	HIGHWAY ADVISORY AHEAD/CAUTION
12/15/2004	12:06	5	HIGHWAY ADVISORY AHEAD / ACCIDENT AT MOSSDALE RD LANES BLOCKED
12/15/2004	12:46	5	STOPPED TRAFFIC AHEAD/CAUTION

Table 3.3.5.8. Speed log for stations capable of activating CMS 2.

LN#	3C			3D			4A			4B		
	1	2	3	1	2	3	1	2	3	1	2	3
	ADVISE CMS 2											
12:04	FLD	FLD	FLD	68	59	68	59	63	59	COM	COM	COM
12:04	FLD	FLD	FLD	68	59	68	59	63	59	COM	COM	COM
12:07	82	68	59	55	48	48	FLD	FLD	FLD	COM	COM	COM
12:10	68	68	59	68	55	9	43	39	0	COM	COM	COM
12:13	75	68	82	55	59	46	12	0	0	COM	COM	COM
12:16	75	63	55	16	14	0	0	11	6	COM	COM	COM
12:19	55	48	39	18	15	7	0	0	5	COM	COM	COM
12:20	39	17	22	0	8	7	12	10	6	COM	COM	COM
12:23	24	91	36	18	16	5	9	7	0	COM	COM	COM
12:26	63	32	41	24	8	25	8	6	8	COM	COM	COM
12:29	30	43	39	7	10	0	9	0	7	COM	COM	COM
12:32	29	51	27	7	7	6	10	##	0	COM	COM	COM
12:35	0	0	18	6	3	0	7	6	7	COM	COM	COM
12:38	0	7	9	5	48	0	11	0	0	COM	COM	COM
12:41	5	0	5	6	6	20	24	22	6	COM	COM	COM
12:44	14	15	0	28	26	22	0	7	12	COM	COM	COM
12:47	9	11	24	0	0	0	13	0	0	COM	COM	COM
12:49	0	0	7	12	7	8	0	6	7	14	11	5
12:50	7	8	0	5	0	0	0	0	0	8	91	43
12:53	0	0	5	0	0	5	20	9	0	6	3	8

Table 3.3.5.9. Speed log related to CMS 5.

LN#	4D			5A			5B			5C			5D					9C					9D					9E											
	1	2	3	1	2	3	1	2	3	1	2	3	1	2	3	4	5	1	2	3	4	5	1	2	3	4	5	1	2	3	4	5							
WARN CMS #5																																							
12:04	COM	COM	COM	COM	COM	COM	COM	COM	COM	COM	COM	COM	COM	COM	COM	COM	COM	COM	COM	COM	COM	COM	COM	COM	COM	COM	COM	COM	COM	COM	COM	COM	COM	COM	COM	COM	COM	COM	
12:04	COM	COM	COM	COM	COM	COM	COM	COM	COM	COM	COM	COM	COM	COM	COM	COM	COM	COM	COM	COM	COM	COM	COM	COM	COM	COM	COM	COM	COM	COM	COM	COM	COM	COM	COM	COM	COM	COM	COM
12:07	COM	COM	COM	COM	COM	COM	COM	COM	COM	COM	COM	COM	COM	COM	COM	COM	COM	COM	COM	COM	COM	COM	COM	COM	COM	COM	COM	COM	COM	COM	COM	COM	COM	COM	COM	COM	COM	COM	COM
12:10	COM	COM	COM	COM	COM	COM	COM	COM	COM	COM	COM	COM	COM	COM	COM	COM	COM	COM	COM	COM	COM	COM	COM	COM	COM	COM	COM	COM	COM	COM	COM	COM	COM	COM	COM	COM	COM	COM	COM
12:13	COM	COM	COM	COM	COM	COM	COM	COM	COM	COM	COM	COM	COM	COM	COM	COM	COM	COM	COM	COM	COM	COM	COM	COM	COM	COM	COM	COM	COM	COM	COM	COM	COM	COM	COM	COM	COM	COM	COM
12:16	COM	COM	COM	COM	COM	COM	COM	COM	COM	COM	COM	COM	COM	COM	COM	COM	COM	COM	COM	COM	COM	COM	COM	COM	COM	COM	COM	COM	COM	COM	COM	COM	COM	COM	COM	COM	COM	COM	COM
12:19	COM	COM	COM	COM	COM	COM	COM	COM	COM	COM	COM	COM	COM	COM	COM	COM	COM	COM	COM	COM	COM	COM	COM	COM	COM	COM	COM	COM	COM	COM	COM	COM	COM	COM	COM	COM	COM	COM	COM
12:20	COM	COM	COM	COM	COM	COM	COM	COM	COM	COM	COM	COM	COM	COM	COM	COM	COM	COM	COM	COM	COM	COM	COM	COM	COM	COM	COM	COM	COM	COM	COM	COM	COM	COM	COM	COM	COM	COM	COM
12:23	COM	COM	COM	COM	COM	COM	COM	COM	COM	COM	COM	COM	COM	COM	COM	COM	COM	COM	COM	COM	COM	COM	COM	COM	COM	COM	COM	COM	COM	COM	COM	COM	COM	COM	COM	COM	COM	COM	COM
12:26	COM	COM	COM	COM	COM	COM	COM	COM	COM	COM	COM	COM	COM	COM	COM	COM	COM	COM	COM	COM	COM	COM	COM	COM	COM	COM	COM	COM	COM	COM	COM	COM	COM	COM	COM	COM	COM	COM	COM
12:29	COM	COM	COM	COM	COM	COM	COM	COM	COM	COM	COM	COM	COM	COM	COM	COM	COM	COM	COM	COM	COM	COM	COM	COM	COM	COM	COM	COM	COM	COM	COM	COM	COM	COM	COM	COM	COM	COM	COM
12:32	COM	COM	COM	COM	COM	COM	COM	COM	COM	COM	COM	COM	COM	COM	COM	COM	COM	COM	COM	COM	COM	COM	COM	COM	COM	COM	COM	COM	COM	COM	COM	COM	COM	COM	COM	COM	COM	COM	COM
12:35	COM	COM	COM	COM	COM	COM	COM	COM	COM	COM	COM	COM	COM	COM	COM	COM	COM	COM	COM	COM	COM	COM	COM	COM	COM	COM	COM	COM	COM	COM	COM	COM	COM	COM	COM	COM	COM	COM	COM
12:38	COM	COM	COM	COM	COM	COM	COM	COM	COM	COM	COM	COM	COM	COM	COM	COM	COM	COM	COM	COM	COM	COM	COM	COM	COM	COM	COM	COM	COM	COM	COM	COM	COM	COM	COM	COM	COM	COM	COM
12:41	COM	COM	COM	COM	COM	COM	COM	COM	COM	COM	COM	COM	COM	COM	COM	COM	COM	COM	COM	COM	COM	COM	COM	COM	COM	COM	COM	COM	COM	COM	COM	COM	COM	COM	COM	COM	COM	COM	COM
12:44	COM	COM	COM	COM	COM	COM	COM	COM	COM	COM	COM	COM	COM	COM	COM	COM	COM	COM	COM	COM	COM	COM	COM	COM	COM	COM	COM	COM	COM	COM	COM	COM	COM	COM	COM	COM	COM	COM	COM
12:47	COM	COM	COM	COM	COM	COM	COM	COM	COM	COM	COM	COM	COM	COM	COM	COM	COM	COM	COM	COM	COM	COM	COM	COM	COM	COM	COM	COM	COM	COM	COM	COM	COM	COM	COM	COM	COM	COM	COM
12:49	0	23	5	14	5	4	5	0	4	0	0	36	0	9	0	0	0	4	0	6	36	7	0	0	0	5	0	0	43	0	4								
12:50	5	0	0	6	0	7	0	0	8	22	0	36	0	37	5	0	9	5	5	9	6	8	0	0	8	0	0	0	0	0	5								
12:53	0	6	5	0	0	0	6	0	4	17	0	7	6	5	5	0	9	11	0	0	9	9	0	0	13	5	0	0	0	7	0	0							

3.4 General Control and Data Logging Issues

A number of general control and architectural issues have been identified which affect the ability of the system to generate and display warning messages. The cases described below revealed two classes of concerns:

- 1) Sensor failure or calibration issues, communications loss or errors, and the method by which sensor data is interpreted by the computer that processes it.
- 2) The ability of Signview to handle multiple trigger events.

3.4.1 Loop Detector Problems Causing CMS Activations

The following cases point out the issue of malfunctions in loop detectors or 170 Controllers that cause CMS activations. In particular, these CMS activations are due to how data is interpreted by the Speed computer and the subsequent the code sent to the Signview computer.

3.4.1.1 August 29, 2004

At 4:07 pm, there was a malfunction associated with Speed Station 2B as indicated by the 0 mph entries shown in Table 3.4.1.1 from the TMS log files. The erroneous detector data were processed as a

“STOPPED TRAFFIC AHEAD” alarm by the TMS computer, which caused speed activation triggers to be sent to the Signview computer for a period of over three hours. The messages displayed on the associated CMSs are shown in

Table 3.4.1.2 as hourly samples of the Signview log during this period. The original TMS log times shown in Table 3.4.1.1 were three minutes ahead of the Signview log time data shown in Table 3.4.1.2. The Signview log has been aligned to the Speed log time.

Table 3.4.1.1. Speed Log (8-29-04).

	2B				2B				2B				2B		
LN#	1	2	3	LN#	1	2	3	LN#	1	2	3	LN#	1	2	3
16:00	75	68	59	17:01	0	0	0	18:00	0	0	0	19:01	0	0	0
16:07	0	0	0	17:04	0	0	0	18:01	0	0	0	19:04	0	0	0
16:10	0	0	0	17:07	0	0	0	18:07	0	0	0	19:07	0	0	0
16:13	0	0	0	17:10	0	0	0	18:10	0	0	0	19:10	0	0	0
16:15	0	0	0	17:13	0	0	0	18:13	0	0	0	19:13	0	0	0
16:16	0	0	0	17:15	0	0	0	18:15	0	0	0	19:15	0	0	0
16:19	0	0	0	17:16	0	0	0	18:16	0	0	0	19:16	0	0	0
16:22	0	0	0	17:19	0	0	0	18:19	0	0	0	19:19	0	0	0
16:25	0	0	0	17:22	0	0	0	18:22	0	0	0	19:22	0	0	0
16:28	0	0	0	17:25	0	0	0	18:25	0	0	0	19:25	0	0	0
16:30	0	0	0	17:28	0	0	0	18:28	0	0	0	19:28	0	0	0
16:31	0	0	0	17:30	0	0	0	18:30	0	0	0	19:30	0	0	0
16:34	0	0	0	17:31	0	0	0	18:31	0	0	0	19:31	0	0	0
16:37	0	0	0	17:34	0	0	0	18:34	0	0	0	19:34	0	0	0
16:40	0	0	0	17:37	0	0	0	18:37	0	0	0	19:37	0	0	0
16:43	0	0	0	17:40	0	0	0	18:40	0	0	0	19:45	75	75	75
16:45	0	0	0	17:43	0	0	0	18:43	0	0	0				
16:46	0	0	0	17:45	0	0	0	18:45	0	0	0				
16:49	0	0	0	17:46	0	0	0	18:46	0	0	0				
16:52	0	0	0	17:49	0	0	0	18:49	0	0	0				
16:55	0	0	0	17:52	0	0	0	18:52	0	0	0				
16:58	0	0	0	17:55	0	0	0	18:55	0	0	0				
17:00	0	0	0	17:58	0	0	0	19:00	0	0	0				

Table 3.4.1.2. Hourly samples from Signview Log.

Date	Time	CMS	Message
8/29/2004	16:09	1	STOPPED TRAFFIC AHEAD/CAUTION
8/29/2004	18:09	1	STOPPED TRAFFIC AHEAD/CAUTION
8/29/2004	19:03	1	STOPPED TRAFFIC AHEAD/CAUTION

3.4.1.2 October 24, 2004

Between 10-24-04 and 3-30-05, the speeds reported by Speed Station 6B were erroneous. The recorded speeds, shown in Table 3.4.1.4, were stuck on a per-lane basis at different speeds. Based on the TMS speed log files, no pattern could be determined that could explain why speed at site 6B would change

from one set of stuck speeds to another set of stuck speeds. However, on 3-19-05 at 2:15 pm, the stuck speeds for Speed Site 6B changed to a set of values that caused a speed alarm and subsequent CMS activation. The TMS log was truncated, but this set of constant speeds lasted from 2:15 pm until 08:14 am the following day. During this period, Signview displayed multiple “STOPPED TRAFFIC AHEAD” or “SLOW TRAFFIC AHEAD” messages on CMS 6, and “HIGHWAY ADVISORY AHEAD” messages on CMS 5. Original TMS log times shown in Table 3.4.1.4 were 26 minutes behind the Signview log time data shown in Table 3.4.1.3. Times were re-aligned to match the TMS speed log.

Table 3.4.1.3. Signview log entries.

Date	Time	CMS	Message
3/19/2005	2:15	6	STOPPED TRAFFIC AHEAD/CAUTION
3/19/2005	2:54	6	STOPPED TRAFFIC AHEAD/CAUTION
3/19/2005	4:42	6	STOPPED TRAFFIC AHEAD/CAUTION
3/19/2005	5:51	6	SLOW TRAFFIC AHEAD/CAUTION
3/20/2005	0:36	6	STOPPED TRAFFIC AHEAD/CAUTION
3/20/2005	1:30	6	STOPPED TRAFFIC AHEAD/CAUTION
3/20/2005	3:27	6	STOPPED TRAFFIC AHEAD/CAUTION
3/20/2005	6:57	6	STOPPED TRAFFIC AHEAD/CAUTION

Table 3.4.1.4. Speed log (3-19-05).

	6B			6B	
LN#	1	2	LN#	1	2
14:15	12	11	19:00	12	11
14:30	12	11	19:15	12	11
14:45	12	11	19:30	12	11
15:00	12	11	19:45	12	11
15:15	12	11	20:00	12	11
15:30	12	11	20:15	12	11
15:45	12	11	20:30	12	11
16:00	12	11	20:45	12	11
16:15	12	11	21:00	12	11
16:30	12	11	21:15	12	11
16:45	12	11	21:45	12	11
17:00	12	11	22:00	12	11
17:15	12	11	22:15	12	11
17:30	12	11	22:30	12	11
17:45	12	11	22:45	12	11
18:00	12	11	23:00	12	11
18:15	12	11	23:15	12	11
18:30	12	11	23:30	12	11
18:45	12	11	23:45	12	11

3.4.1.3 February 22, 2005

From 2-22-05 at 2:15 pm until 3-31-05 at 11:45 pm, speed station 6C reported inconsistent speed data. Log data in Table 3.4.1.5 shows speeds recorded in the range of 100-205 mph. These speeds did not

cause Signview to display warning messages, since data over 150 mph is interpreted as an error. This type of error, however, could potentially cause false speed activations. Errors of this type would likely only be caught by TMC staff if a special effort was made to time-realign the TMS and Signview log files.

Table 3.4.1.5. TMS Speed Log (3-31-05).

	6B		6C		7A	
LN#	1	2	1	2	1	2
00:00	68	59	154	13	75	75
00:15	68	59	59	8	63	63
00:30	68	59	102	0	75	75
00:45	68	59	41	82	82	68
01:00	68	59	22	22	75	63
01:15	68	59	137	14	75	59
01:30	68	59	17	8	75	68
01:45	68	59	75	17	75	63
02:00	68	59	16	6	68	59
02:15	68	59	91	0	75	75
02:30	68	59	52	0	68	59
02:45	FLD	FLD	17	6	68	75
03:00	68	59	82	29	68	75
03:15	68	59	19	0	68	59
03:30	FLD	FLD	46	0	82	68
03:39	68	59	26	8	68	68
03:45	68	59	15	15	68	75
04:00	68	59	75	19	75	82
04:15	68	59	59	0	68	63
04:30	68	59	82	52	75	68
04:45	68	59	FLD	FLD	68	59
05:00	68	59	164	0	68	75
05:15	68	59	164	154	82	63
05:30	68	59	52	7	68	59
05:45	68	59	43	0	75	63
06:00	68	59	17	0	82	75
06:15	68	59	17	55	63	59
06:30	68	59	154	10	75	68
06:45	68	59	52	7	68	63
07:00	68	59	205	0	75	68
07:15	68	59	205	17	68	63
07:30	68	59	33	46	75	63
07:36	68	59	17	137	68	55
07:39	68	59	28	13	68	68
07:42	68	59	137	6	63	51
07:45	68	59	154	0	68	63
07:48	68	59	154	18	82	63
08:00	68	59	52	0	68	59
08:15	68	59	75	102	63	59
08:30	68	59	205	154	75	82
08:45	68	59	26	46	82	68
09:00	68	59	205	91	68	63
09:15	68	59	52	17	68	59
09:30	68	59	52	75	75	63
10:00	FLD	FLD	16	154	63	59
10:15	68	59	82	102	75	75
10:30	68	59	68	154	63	63
10:45	68	59	75	164	91	68
11:00	68	59	75	17	75	63
11:15	68	59	63	52	91	63
11:30	68	59	82	154	75	63
11:45	68	59	75	102	68	59
12:00	68	59	9	52	82	59
12:15	68	59	75	17	68	59
12:30	68	59	75	17	82	68
12:45	68	59	75	154	75	55
13:15	68	59	82	17	68	55
13:30	68	59	68	154	63	68
13:45	68	59	22	52	82	82
14:00	68	59	91	52	82	59
14:15	68	59	30	154	75	59
14:30	68	59	75	154	75	68
14:45	68	59	82	164	68	63
15:00	68	59	FLD	FLD	68	63
15:15	68	59	82	137	82	68
15:30	68	59	82	52	82	68
15:45	68	59	75	154	75	63
16:00	68	59	75	205	82	59
16:30	68	59	75	205	68	68
16:45	68	59	68	137	75	75
17:00	68	59	26	17	75	59
17:15	68	59	68	117	68	75
17:30	68	59	164	137	82	75
17:45	68	59	39	154	75	59
18:00	68	59	55	164	68	68
18:15	68	59	19	205	82	59
18:30	68	59	30	17	68	59
18:45	68	59	205	137	75	63
19:00	68	59	91	52	75	75
19:15	68	59	14	17	75	68
19:45	68	59	205	17	68	59
20:00	68	59	15	164	75	82
20:15	68	59	9	59	82	68
20:30	68	59	102	12	75	63
20:45	68	59	82	14	63	63
21:00	68	59	23	23	75	63
21:12	68	59	14	20	68	63
21:15	68	59	117	24	82	63
21:30	68	59	205	17	75	68
21:45	68	59	91	7	75	59
22:00	68	59	82	22	68	59
22:15	68	59	22	16	68	55
22:18	68	59	23	8	82	82
22:30	68	59	51	7	75	68
22:39	68	59	25	7	75	82
23:00	68	59	75	51	91	91
23:15	68	59	52	5	59	75
23:30	68	59	205	39	82	68
23:45	68	59	117	32	75	91

3.4.2 Conflicts Between Speed Activation and Weather Activation

The following cases demonstrate issues in the prioritization of speed and weather activations. Potential problems are identified during periods of partial sensor or communications failure. Situations of this type are common during fog seasons.

3.4.2.1 February 25, 2004

This event occurred in the middle of the 2004 fog season. Prior to 6:45 am, a high wind warning generated by Weather Station 4 and displayed on CMS 4. From 6:45 am to 8:35 am, a speed event occurred that overwrote the wind event. The wind warning was reactivated after the speed event concluded, since high winds were still present. The original weather log and TMS speed log time data were one and four minutes behind Signview log time, respectively. The times shown in Table 3.4.2.2 and

Table 3.4.2.3 have been aligned to Signview time. This priority is consistent with the design decisions implemented for the CAWS by Signview.

Table 3.4.2.1. Signview Log.

Date	Time	CMS	Message
2/25/2004	6:46	4	GUSTY WIND WARNING
2/25/2004	8:04	4	SLOW TRAFFIC AHEAD/CAUTION
2/25/2004	8:07	4	STOPPED TRAFFIC AHEAD/CAUTION
2/25/2004	8:28	4	SLOW TRAFFIC AHEAD/CAUTION
2/25/2004	8:34	4	GUSTY WIND WARNING

Table 3.4.2.2. Weather Log (2-25-04).

Time	SITE 4									
	MC DB	Vis [m]	Wind [m/s]	Wind Dir [deg]	Wet Temp [C]	Dry Temp [C]	Rel Hum [%]	Bar Press [KPa]	Rain Vol [inch]	Rain Rate [inch/h]
6:46:00	8	2982	11.5	129	12.5	12.5	100	1002.5	0	0
6:51:00	8	388.6	11.9	129	12.3	12.3	100	1002.5	0	0
6:56:00	8	377.8	12.9	128	12.2	12.2	100	1002.2	0	0
7:01:00	8	365.4	13.1	126	12	12	100	1002.2	0	0.12
7:06:00	8	368.9	13.3	125	12	12	100	1002.2	0.01	0
7:11:00	8	384.3	13.9	125	11.9	11.9	100	1002.1	0.01	0
7:16:00	8	395.9	13.9	125	11.9	11.9	100	1002.1	0.01	0
7:21:00	8	379.2	14.6	125	11.9	11.9	100	1002	0.01	0
7:26:00	8	368.6	14.2	123	11.8	11.8	100	1001.9	0.01	0
7:31:00	8	366.3	14.3	124	11.7	11.7	100	1002	0.01	0
7:36:00	8	3735	14.1	125	11.7	11.7	100	1002.2	0.01	0
7:41:00	8	4342	12.1	124	11.7	11.7	100	1002.4	0.01	0
7:46:00	8	7490	13.2	121	11.7	11.7	100	1002.2	0.01	0
7:51:00	8	9370	13.4	119	11.8	11.8	100	1001.6	0.01	0

7:56:00	8	10403	13.4	121	11.8	11.8	100	1001.5	0.01	0
8:01:00	8	7294	13.6	120	11.8	11.8	100	1001.2	0.01	0
8:06:00	8	6188	14.2	122	12	12	100	1001	0.01	0
8:11:00	8	7358	14.3	121	12	12	100	1001	0.01	0
8:16:00	8	10547	13.5	119	12.1	12.1	100	1000.9	0.01	0
8:21:00	8	12139	12.8	119	12.1	12.1	100	1000.8	0.01	0
8:26:00	8	9114	12.8	119	12.1	12.1	100	1000.8	0.01	0
8:31:00	8	10118	13.4	121	12.1	12.1	100	1001	0.01	0
8:36:00	8	17187	14	120	12.1	12.1	100	1000.9	0.01	0

Table 3.4.2.3. Speed Log (2-25-04).

	4D			5A		
LN#	1	2	3	1	2	3
07:49	68	68	51	68	63	55
08:04	23	26	34	24	33	37
08:05	19	20	17	32	39	51
08:08	8	6	0	13	13	0
08:11	15	11	11	15	22	18
08:14	19	12	27	39	37	39
08:17	26	8	20	32	34	36
08:19	12	9	7	22	15	14
08:20	19	14	22	22	22	26
08:23	12	9	6	11	11	0
08:26	FLD	FLD	FLD	17	16	8
08:29	12	15	12	33	30	21
08:32	36	39	30	55	41	41
08:34	55	48	43	68	68	68

3.4.2.2 January 21, 2004

The Signview log entries shown in Table 3.4.2.4 and

Table 3.4.2.6 indicate that at 4:56 am a Level 1 fog message was sent to CMS 5, and was shortly after sent to CMS 9. The corresponding weather logs for CMS 5 and CMS 9 are shown in Table 3.4.2.8. During this fog event, a speed event occurred at 5:02 am but the fog activation appears to continually overwrite the speed activation. The TMS speed logs indicate that the CMS displayed “DENSE FOG AHEAD, ADVISE 45 MPH” when actual traffic speeds were less than 45 mph. During the speed event the CMS should have displayed “STOPPED TRAFFIC AHEAD, CAUTION” or “SLOW TRAFFIC AHEAD, CAUTION”. This situation seemed to contradict the previously established Signview priority logic. Further investigation revealed an apparently unforeseen problem related to the communications protocols between the Signview computer and the TMS and QCMS computers.

The Signview source code revealed that the Signview computer acts upon the most recently received alarm flags provided to it by the TMS and QCMS computers within a possibly inconsistent time window

established by a software timing loop. It is possible that a weather alarm can supercede a speed alarm, despite control logic to the contrary, if a weather alarm is received from the QCMS computer within the polling interval, but an ongoing speed alarm is not. The result can be messages that may appear to be randomly alternating between weather and speed warnings, during a period in which a continuous speed warning should have been displayed. Supporting data for this observation are in the tables below. Table 3.4.2.4 shows the display sequence for CMS 5.

Table 3.4.2.6 shows the sequence for CMS 9.

Both the speed and fog conditions, denoted by yellow or red table entries, were present for almost the entire duration from 4:57 am to 8:55 am for CMS 5 and CMS 9. In the tables below, the original weather log is two minutes faster than the Signview log, and the original TMS speed log is 13 minutes faster than the Signview log. Table 3.4.2.5 through Table 3.4.2.8 have been aligned to Signview time.

Table 3.4.2.4. Signview Log entries for CMS 5, 4:56 am – 8:55 am.

Date	Time	CMS	Message
1/21/2004	4:56	5	DENSE FOG/ADVISE 45MPH
1/21/2004	5:02	5	STOPPED TRAFFIC AHEAD/CAUTION
1/21/2004	5:08	5	DENSE FOG/ADVISE 30MPH
1/21/2004	5:14	5	DENSE FOG/ADVISE 45MPH
1/21/2004	5:21	5	STOPPED TRAFFIC AHEAD/CAUTION
1/21/2004	5:53	5	DENSE FOG/ADVISE 45MPH
1/21/2004	5:57	5	STOPPED TRAFFIC AHEAD/CAUTION
1/21/2004	6:07	5	DENSE FOG/ADVISE 45MPH
1/21/2004	6:27	5	SLOW TRAFFIC AHEAD/CAUTION
1/21/2004	6:30	5	DENSE FOG/ADVISE 45MPH
1/21/2004	7:06	5	DENSE FOG/ADVISE 45MPH
1/21/2004	7:18	5	DENSE FOG/ADVISE 45MPH
1/21/2004	8:55	5	DENSE FOG/ADVISE 45MPH

Table 3.4.2.5. Speed log for stations which could activate CMS 5 (1-21-04).

LN#	4D			5A			5B			5C			5D					9C					9D					9E					
	1	2	3	1	2	3	1	2	3	1	2	3	1	2	3	4	5	1	2	3	4	5	1	2	3	4	5	1	2	3	4	5	
	CMS 5															CMS 5 & CMS 9																	
04:47	68	63	68	63	68	68	75	63	75	59	68	46	82	75	63	68	59	75	68	63	63	68	75	68	59	43	43	68	91	48	75	48	
05:02	68	68	63	68	82	63	68	59	59	68	82	59	34	22	15	25	41	48	48	26	15	12	59	59	46	18	19	59	75	11	37	13	A
05:02	63	68	63	68	59	55	63	63	55	63	75	55	46	25	26	24	39	43	48	39	17	23	59	55	26	23	27	51	63	19	41	22	A
05:05	82	68	55	75	75	59	82	63	63	63	75	59	51	41	22	32	33	48	41	29	18	12	63	48	29	23	23	55	75	19	48	20	A
05:14	75	75	68	75	63	63	75	68	63	55	51	51	33	26	6	0	8	41	39	41	6	16	63	55	48	12	12	75	75	13	48	20	A
05:17	75	59	55	75	68	63	68	63	55	68	63	48	48	43	16	14	20	30	41	17	6	0	63	55	41	23	21	55	68	29	46	30	A
05:17	82	63	51	75	63	34	59	59	51	59	68	48	46	23	6	14	26	41	43	33	20	19	51	59	41	17	11	59	59	26	39	25	A
05:20	75	75	59	68	75	51	68	68	59	59	63	55	55	63	13	12	19	63	51	51	41	23	55	55	32	23	0	68	68	26	46	27	M
05:23	75	75	59	75	68	59	68	75	55	55	59	48	37	37	7	8	16	46	51	37	26	18	59	55	39	19	9	55	75	25	46	26	A
05:26	75	75	68	68	75	63	75	68	46	68	63	68	68	55	13	15	26	41	51	39	15	19	59	55	23	8	12	63	63	25	46	26	M
05:29	75	68	59	68	75	68	75	63	63	59	68	55	39	46	7	29	26	34	46	25	5	8	59	48	51	15	15	48	63	9	33	9	A
05:32	75	68	63	75	75	63	82	68	82	75	75	59	43	33	9	13	5	30	46	29	6	14	48	46	30	7	6	55	82	20	41	10	A

05:32	75	68	59	75	75	63	68	63	51	68	75	55	41	43	6	10	16	26	32	20	16	0	51	39	43	14	12	46	63	16	55	15	A
05:35	68	59	59	59	51	63	68	55	51	59	63	43	43	24	6	6	6	37	39	36	11	8	59	55	51	13	0	39	68	14	8	15	A
05:38	75	75	63	63	63	59	82	68	55	59	59	39	27	21	0	0	9	41	43	37	16	16	FLD	FLD	FLD	FLD	FLD	55	75	12	46	16	A
05:41	55	68	51	75	75	55	FLD	FLD	FLD	51	48	32	46	34	12	19	22	33	37	26	14	12	59	51	48	12	11	59	68	25	46	26	A
05:44	75	59	59	59	55	0	75	59	51	68	68	63	37	91	9	8	7	37	41	17	6	8	51	55	0	20	18	51	46	12	36	22	A
05:47	75	68	63	68	63	68	68	68	59	51	41	36	41	26	6	15	19	48	46	29	5	12	63	48	43	22	28	55	75	15	36	25	A
05:47	68	59	59	63	59	51	63	55	55	51	63	43	34	34	16	7	19	43	39	37	29	32	63	59	43	18	22	55	63	5	46	0	A
05:50	75	75	68	63	59	59	63	75	68	41	43	37	51	48	24	30	30	41	48	37	0	5	51	55	37	11	7	48	59	22	37	26	A
05:53	75	59	59	63	68	55	59	63	55	9	34	11	46	48	14	8	0	37	39	24	5	6	51	48	34	16	20	51	68	16	46	10	A
05:56	63	46	48	51	51	41	59	55	63	46	59	13	37	32	9	9	0	30	34	7	5	9	63	51	32	22	21	10	68	33	51	36	A
05:59	68	59	59	55	63	51	68	75	63	32	34	12	39	37	15	18	32	43	36	30	7	0	51	41	41	32	19	48	63	36	41	36	A
06:02	75	68	59	68	10	63	91	63	59	19	32	13	41	34	16	16	25	41	43	26	9	0	55	55	55	30	28	63	55	0	41	13	A
06:02	75	59	59	68	68	59	68	51	51	32	48	15	36	28	8	8	22	41	41	30	22	12	68	63	41	22	24	55	59	19	51	32	A
06:05	68	68	75	68	63	63	68	63	48	51	59	27	51	48	18	36	36	22	43	25	8	8	51	46	34	23	23	7	63	15	37	13	A
06:08	75	59	59	75	75	59	75	63	51	28	46	6	43	29	9	21	15	43	41	27	17	20	51	46	36	15	12	68	75	22	39	20	A
06:12	55	55	41	68	55	43	63	59	55	63	59	63	46	27	7	7	12	34	43	32	16	15	51	41	25	13	14	51	48	23	55	15	A
06:17	68	59	51	68	68	63	68	68	59	75	75	63	48	46	11	30	32	37	46	27	19	22	46	39	30	7	11	48	68	17	37	11	A
06:18	68	63	55	75	63	14	63	75	59	55	68	48	39	37	21	27	34	43	51	13	13	0	59	55	48	26	23	63	75	23	43	21	A
06:21	75	63	59	68	75	63	68	68	55	63	68	51	55	39	14	21	20	55	59	46	19	20	48	51	46	17	25	41	55	10	22	13	M
06:24	68	68	59	68	75	59	63	59	48	68	75	51	55	32	9	7	12	41	51	43	23	19	46	51	34	20	20	41	51	20	39	30	M
06:27	82	75	0	68	68	68	63	59	63	55	68	51	46	41	17	16	11	55	51	55	18	16	63	46	36	36	0	63	68	7	30	18	A
06:30	68	68	63	75	75	63	68	59	55	55	75	51	63	75	22	33	0	55	43	33	14	16	51	55	41	12	14	63	63	0	29	25	M
06:32	75	63	59	75	75	63	75	63	68	59	75	59	75	63	32	17	33	46	48	36	21	11	51	48	46	20	19	51	55	9	51	10	A
06:33	75	63	59	68	68	68	68	59	51	63	68	63	63	68	34	9	27	41	37	25	0	0	55	55	41	10	6	51	59	22	39	30	A
06:36	68	63	63	68	63	55	68	63	51	63	75	51	63	63	51	13	8	43	51	32	23	22	FLD	FLD	FLD	FLD	FLD	59	55	18	37	17	M
06:39	75	63	63	68	75	7	68	63	55	63	68	59	68	46	43	28	24	43	43	30	26	20	59	55	37	28	27	51	59	0	39	9	A
06:42	68	63	55	68	11	8	63	51	48	59	63	51	75	75	51	34	36	48	63	34	23	22	59	55	37	27	28	63	75	32	63	43	M
06:45	75	63	7	68	63	55	68	59	46	75	68	55	51	59	7	10	18	48	48	43	33	26	55	59	51	32	36	63	82	25	51	28	A
06:47	75	63	59	75	91	63	68	68	55	68	68	43	55	48	15	12	26	55	46	32	20	14	63	68	55	34	43	63	59	10	43	26	M
06:49	68	63	51	68	68	63	75	55	51	59	68	63	51	68	34	11	29	55	55	43	23	39	59	43	43	27	39	59	75	37	55	41	M
06:53	75	59	59	82	63	59	75	68	68	63	68	59	63	48	27	11	15	FLD	FLD	FLD	FLD	FLD	63	59	37	13	11	46	68	37	39	36	M
06:56	75	68	63	75	75	63	75	68	59	63	63	55	46	43	32	19	6	41	55	41	39	26	55	63	46	29	37	63	75	46	55	41	A
06:59	68	63	55	63	68	63	68	63	63	63	75	63	63	63	51	51	48	55	59	51	46	41	75	59	51	28	34	75	75	36	63	41	M
07:02	75	59	59	75	68	0	75	63	55	59	63	63	82	75	68	55	51	51	68	46	48	55	68	55	51	33	30	63	82	36	55	37	M
07:05	75	75	63	68	68	46	68	75	63	82	68	55	68	82	63	63	59	68	68	68	63	59	68	63	46	29	37	68	68	46	59	46	M
07:17	75	68	51	75	63	55	82	59	59	68	91	63	75	91	63	75	63	63	63	55	51	55	68	75	68	75	75	63	75	59	59	51	

Table 3.4.2.6. Signview Log for CMS 9, 4:56 am – 8:55 am.

Date	Time	CMS	Message
1/21/2004	4:57	9	DENSE FOG/ADVISE 30MPH
1/21/2004	5:02	9	STOPPED TRAFFIC AHEAD/CAUTION
1/21/2004	5:09	9	SLOW TRAFFIC AHEAD/CAUTION
1/21/2004	5:11	9	STOPPED TRAFFIC AHEAD/CAUTION
1/21/2004	6:21	9	SLOW TRAFFIC AHEAD/CAUTION
1/21/2004	6:24	9	STOPPED TRAFFIC AHEAD/CAUTION
1/21/2004	6:30	9	DENSE FOG/ADVISE 45MPH
1/21/2004	6:38	9	SLOW TRAFFIC AHEAD/CAUTION
1/21/2004	6:41	9	STOPPED TRAFFIC AHEAD/CAUTION
1/21/2004	6:47	9	DENSE FOG/ADVISE 45MPH
1/21/2004	7:18	9	DENSE FOG/ADVISE 45MPH
1/21/2004	8:49	9	DENSE FOG/ADVISE 45MPH

Table 3.4.2.7. Speed log for stations which could activate CMS 9 (1-21-04).

	9A		9B		9C					9D					9E						
LN#	1	2	1	2	1	2	3	4	5	1	2	3	4	5	1	2	3	4	5		
	CMS 9				CMS 5 & CMS 9																
04:47	63	59	63	68	75	68	63	63	68	75	68	59	43	43	68	91	48	75	48		
05:02	59	75	55	55	48	48	26	15	12	59	59	46	18	19	59	75	11	37	13	A	
05:02	63	55	55	63	43	48	39	17	23	59	55	26	23	27	51	63	19	41	22	A	
05:05	59	55	24	29	48	41	29	18	12	63	48	29	23	23	55	75	19	48	20	A	
05:14	68	63	12	24	41	39	41	6	16	63	55	48	12	12	75	75	13	48	20	A	
05:17	46	48	27	36	30	41	17	6	0	63	55	41	23	21	55	68	29	46	30	A	
05:17	43	46	5	26	41	43	33	20	19	51	59	41	17	11	59	59	26	39	25	A	
05:20	43	43	18	39	63	51	51	41	23	55	55	32	23	0	68	68	26	46	27	A	
05:23	43	43	34	43	46	51	37	26	18	59	55	39	19	9	55	75	25	46	26	A	
05:26	15	30	22	37	41	51	39	15	19	59	55	23	8	12	63	63	25	46	26	A	
05:29	36	37	14	26	34	46	25	5	8	59	48	51	15	15	48	63	9	33	9	A	
05:32	43	41	6	19	30	46	29	6	14	48	46	30	7	6	55	82	20	41	10	A	
05:32	30	34	8	11	26	32	20	16	0	51	39	43	14	12	46	63	16	55	15	A	
05:35	11	28	12	11	37	39	36	11	8	59	55	51	13	0	39	68	14	8	15	A	
05:38	10	21	6	9	41	43	37	16	16	FLD	FLD	FLD	FLD	FLD	55	75	12	46	16	A	
05:41	FLD	FLD	12	15	33	37	26	14	12	59	51	48	12	11	59	68	25	46	26	A	
05:44	16	23	17	23	37	41	17	6	8	51	55	0	20	18	51	46	12	36	22	A	
05:47	12	18	##	8	48	46	29	5	12	63	48	43	22	28	55	75	15	36	25	A	
05:47	9	11	12	20	43	39	37	29	32	63	59	43	18	22	55	63	5	46	0	A	
05:50	6	15	25	24	41	48	37	0	5	51	55	37	11	7	48	59	22	37	26	A	
05:53	13	22	17	24	37	39	24	5	6	51	48	34	16	20	51	68	16	46	10	A	
05:56	12	15	15	21	30	34	7	5	9	63	51	32	22	21	10	68	33	51	36	A	
05:59	6	16	8	20	43	36	30	7	0	51	41	41	32	19	48	63	36	41	36	A	
06:02	14	24	12	26	41	43	26	9	0	55	55	55	30	28	63	55	0	41	13	A	
06:02	26	26	8	23	41	41	30	22	12	68	63	41	22	24	55	59	19	51	32	A	
06:05	9	18	26	26	22	43	25	8	8	51	46	34	23	23	7	63	15	37	13	A	
06:08	19	22	21	24	43	41	27	17	20	51	46	36	15	12	68	75	22	39	20	A	
06:12	13	23	10	15	34	43	32	16	15	51	41	25	13	14	51	48	23	55	15	A	
06:17	13	20	13	20	37	46	27	19	22	46	39	30	7	11	48	68	17	37	11	A	
06:18	7	21	20	32	43	51	13	13	0	59	55	48	26	23	63	75	23	43	21	A	
06:21	36	39	13	26	55	59	46	19	20	48	51	46	17	25	41	55	10	22	13	A	
06:24	29	41	0	24	41	51	43	23	19	46	51	34	20	20	41	51	20	39	30	A	
06:27	10	33	15	17	55	51	55	18	16	63	46	36	36	0	63	68	7	30	18	A	
06:30	20	22	18	27	55	43	33	14	16	51	55	41	12	14	63	63	0	29	25	A	
06:32	17	23	21	28	46	48	36	21	11	51	48	46	20	19	51	55	9	51	10	A	
06:33	13	32	25	37	41	37	25	0	0	55	55	41	10	6	51	59	22	39	30	A	
06:36	9	26	26	33	43	51	32	23	22	FLD	FLD	FLD	FLD	FLD	59	55	18	37	17	A	
06:39	17	23	26	25	43	43	30	26	20	59	55	37	28	27	51	59	0	39	9	A	
06:42	20	30	39	39	48	63	34	23	22	59	55	37	27	28	63	75	32	63	43	A	
06:45	37	37	15	32	48	48	43	33	26	55	59	51	32	36	63	82	25	51	28	A	
06:47	37	37	14	34	55	46	32	20	14	63	68	55	34	43	63	59	10	43	26	A	
06:49	22	39	30	36	55	55	43	23	39	59	43	43	27	39	59	75	37	55	41	A	
06:53	26	37	0	26	FLD	FLD	FLD	FLD	FLD	63	59	37	13	11	46	68	37	39	36	A	
06:56	41	43	6	6	41	55	41	39	26	55	63	46	29	37	63	75	46	55	41	A	
06:59	11	17	43	39	55	59	51	46	41	75	59	51	28	34	75	75	36	63	41	A	
07:02	41	48	51	48	51	68	46	48	55	68	55	51	33	30	63	82	36	55	37	M	
07:05	46	48	51	59	68	68	68	63	59	68	63	46	29	37	68	68	46	59	46	M	
07:17	43	55	59	68	63	63	55	51	55	68	75	68	75	75	63	75	59	59	51		

Table 3.4.2.8. Weather Log for CMS 5 and CMS 9 (1-21-04).

Time	SITE 5										SITE 9									
	MC DB	Vis [m]	Wind [m/s]	Wind Dir [deg]	Wet Temp [C]	Dry Temp [C]	Rel Hum [%]	Bar Press [KPa]	Rain Vol [inch]	Rain Rate [inch/h]	MC DB	Vis [m]	Wind [m/s]	Wind Dir [deg]	Wet Temp [C]	Dry Temp [C]	Rel Hum [%]	Bar Press [KPa]	Rain Vol [inch]	Rain Rate [inch/h]
4:57:00	1	85	1	293	2.8	1.2	89	1045.3	0	0	2	49.1	1.3	275	2.9	2.8	99	1017.1	0	0
5:02:00	1	77.1	0.9	271	2.7	1	89	1045.4	0	0	2	49.5	1.2	298	2.5	2.2	98	1017.2	0	0
5:07:00	1	71.9	0.8	267	2.6	1	89	1045.4	0	0	2	41.4	1.2	288	2.4	2.1	98	1017.2	0	0
5:12:00	2	57	0.8	261	2.7	1	89	1045.4	0	0	2	37.8	0.7	297	2.5	2.3	99	1017.2	0	0
5:17:00	2	50.7	0.8	298	2.8	1.1	89	1045.4	0	0	2	41.6	0.1	329	2.5	2.4	99	1017.2	0	0
5:22:00	1	68.5	1.5	323	2.7	1.1	89	1045.4	0	0	2	43.4	0	336	2.6	2.4	99	1017.3	0	0
5:27:00	1	86.7	1.5	325	2.9	1.3	89	1045.4	0	0	2	48.7	0.1	178	2.6	2.5	99	1017.3	0	0
5:32:00	1	99.8	1.4	343	3	1.3	89	1045.5	0	0	2	55.6	0.3	150	2.7	2.5	99	1017.4	0	0
5:37:00	1	102.6	0.9	79	3.2	1.5	89	1045.5	0	0	1	73.2	0.9	132	2.9	2.7	99	1017.4	0	0
5:42:00	1	94.5	0.6	321	3.2	1.5	89	1045.6	0	0	1	61.6	0.6	115	3	2.9	99	1017.4	0	0
5:47:00	1	83.9	0.8	225	3.2	1.6	89	1045.5	0	0	2	59.2	0.6	105	3.1	2.9	99	1017.4	0	0
5:52:00	1	81.7	0.9	279	3.2	1.6	89	1045.5	0	0	1	69.6	0.2	140	3.1	3	99	1017.4	0	0
5:57:00	1	97.8	0.9	334	3.4	1.8	90	1045.5	0	0	1	90.9	1	133	3.2	3	99	1017.4	0	0
6:02:00	1	104.8	0.1	1	3.4	1.9	90	1045.5	0	0	1	90.4	0.9	120	3.3	3.2	99	1017.3	0	0
6:07:00	1	109.7	0.5	121	3.5	1.9	90	1045.5	0	0	1	113.8	1	103	3.3	3.2	99	1017.3	0	0
6:12:00	1	99.1	1.8	112	3.4	1.9	90	1045.3	0	0	1	112.9	1.5	114	3.3	3.1	99	1017.2	0	0
6:17:00	1	87.2	1.8	120	3.4	1.8	90	1045.4	0	0	1	113.3	1.5	110	3.2	3.1	99	1017.2	0	0
6:22:00	1	92.3	1.1	120	3.4	1.9	90	1045.5	0	0	1	132.9	1.3	107	3.3	3.2	99	1017.3	0	0
6:27:00	1	95.2	1.1	114	3.4	1.8	90	1045.5	0	0	1	140.3	1.2	119	3.3	3.2	100	1017.4	0	0
6:32:00	1	114.3	1.5	120	3.2	1.7	90	1045.5	0	0	1	138	1.4	127	3.2	3.2	100	1017.4	0	0
6:37:00	1	108.5	1.1	121	3.1	1.6	90	1045.6	0	0	1	142.7	1.1	117	3.1	3.1	100	1017.4	0	0
6:42:00	1	111.2	0.5	314	2.9	1.4	90	1045.8	0	0	0	152.4	0.3	65	3	2.9	99	1017.5	0	0
6:47:00	1	134.1	1.3	318	3	1.5	90	1045.9	0	0	1	123.2	0.5	269	2.9	2.8	99	1017.6	0	0
6:52:00	1	146.6	1.3	320	3.1	1.6	90	1045.8	0	0	1	90.3	0.2	178	2.8	2.7	99	1017.6	0	0
6:57:00	1	142.7	1.1	335	3.3	1.8	90	1045.8	0	0	1	117.8	0.7	110	2.8	2.8	99	1017.6	0	0
7:02:00	1	121.2	1.2	303	3.4	1.9	90	1045.9	0	0	1	115.2	0.2	55	2.9	2.9	100	1017.7	0	0
7:07:00	0	154.8	0.6	49	3.4	2	91	1045.9	0	0	1	123.5	0.9	49	2.9	2.9	100	1017.7	0	0
7:12:00	0	153.4	0.7	100	3.3	1.9	91	1045.9	0	0	0	192.4	1	44	3	3	100	1017.7	0	0
7:17:00	1	142.7	0.4	106	3.1	1.8	91	1046	0	0	0	242.6	1.2	47	3.1	3.1	100	1017.7	0	0
7:22:00	0	157.3	0.4	319	3	1.6	91	1046.2	0	0	0	195.1	0.6	16	3	3	100	1017.9	0	0
7:27:00	1	129.1	1.4	312	2.9	1.5	91	1046.3	0	0	1	127.2	1	315	2.7	2.7	100	1018.1	0.006	0.12
7:32:00	1	109.9	1.2	314	2.8	1.4	91	1046.3	0	0	1	120.7	0.7	312	2.4	2.4	100	1018.2	0.01	0
7:37:00	1	74.7	1.2	290	2.6	1.2	91	1046.5	0	0	1	114.9	1.8	294	2.2	2.2	100	1018.3	0.01	0
7:42:00	1	70.7	1.4	293	2.3	1	91	1046.5	0	0	1	150.8	1.6	298	2	2	100	1018.3	0.01	0
7:47:00	1	90.4	0.9	290	2.4	1	91	1046.5	0	0	1	134.6	1.5	297	1.9	1.9	100	1018.4	0.01	0
7:52:00	1	86.1	1.4	280	2.3	1	91	1046.7	0	0	1	98.3	2.1	289	1.9	1.9	100	1018.5	0.01	0
7:57:00	1	83.3	1.2	276	2.2	0.9	91	1046.8	0	0	1	92.2	1.7	299	1.8	1.8	100	1018.7	0.01	0
8:02:00	1	93.9	1	278	2.2	0.9	91	1046.9	0	0	1	116.9	1	313	1.8	1.8	100	1018.7	0.01	0

3.4.2.3 November 17, 2004

Table 3.4.2.9 is excerpted from the Signview log to show an activation sequence starting at 3:33 am. The weather log data shown in Table 3.4.2.10 indicates reduced visibility which initiated a fog activation of CMS 5 at 3:33 am. Table 3.4.2.11 shows the speed log associated with this event. At 5:03 am, a speed event was activated, but it was overwritten three minutes later by the fog event. As shown in Table 3.4.2.9, the two alarms continued to alternate until 7:03 am. Considering the stopped traffic condition

approximately 0.2 miles ahead, the 45 mph advised speed may have been inappropriate. The original weather log and speed log time data are two minutes and three minutes behind the Signview log respectively. The weather log times in Table 3.4.2.10 and speed log times in Table 3.4.2.11 have been aligned to Signview times shown in Table 3.4.2.10.

Table 3.4.2.9. Signview Log.

Date	Time	CMS	Message
11/17/2004	3:33	5	DENSE FOG/ADVISE 45MPH
11/17/2004	5:03	5	STOPPED TRAFFIC AHEAD/CAUTION
11/17/2004	5:06	5	DENSE FOG/ADVISE 45MPH
11/17/2004	5:33	5	STOPPED TRAFFIC AHEAD/CAUTION
11/17/2004	5:36	5	DENSE FOG/ADVISE 45MPH
11/17/2004	5:45	5	STOPPED TRAFFIC AHEAD/CAUTION
11/17/2004	6:00	5	DENSE FOG/ADVISE 45MPH
11/17/2004	6:06	5	STOPPED TRAFFIC AHEAD/CAUTION
11/17/2004	6:09	5	DENSE FOG/ADVISE 45MPH
11/17/2004	6:12	5	STOPPED TRAFFIC AHEAD/CAUTION
11/17/2004	6:15	5	DENSE FOG/ADVISE 45MPH
11/17/2004	6:18	5	SLOW TRAFFIC AHEAD/CAUTION
11/17/2004	6:21	5	DENSE FOG/ADVISE 45MPH
11/17/2004	6:24	5	STOPPED TRAFFIC AHEAD/CAUTION
11/17/2004	6:27	5	DENSE FOG/ADVISE 45MPH
11/17/2004	6:30	5	STOPPED TRAFFIC AHEAD/CAUTION
11/17/2004	6:42	5	DENSE FOG/ADVISE 45MPH
11/17/2004	6:51	5	STOPPED TRAFFIC AHEAD/CAUTION
11/17/2004	7:03	5	DENSE FOG/ADVISE 45MPH

Table 3.4.2.10. Weather Log (11-17-04).

Time	SITE 5									
	MC DB	Vis [m]	Wind [m/s]	Wind Dir [deg]	Wet Temp [C]	Dry Temp [C]	Rel Hum [%]	Bar Press [KPa]	Rain Vol [inch]	Rain Rate [inch/h]
3:28:00	0	167.8	1.8	65	8.3	5.2	81	1026.4	0	0
3:33:00	1	122.8	1.9	66	8.3	5.2	81	1026.4	0	0
3:38:00	1	114	2	75	8.2	5.1	81	1026.4	0	0
3:43:00	1	116.3	1.9	76	8.3	5.3	82	1026.4	0	0
3:48:00	1	121	1.8	75	8.5	5.5	81	1026.4	0	0
3:53:00	1	114.3	1.8	76	8.6	5.5	81	1026.5	0	0
3:58:00	1	96.3	1.7	79	8.7	5.6	81	1026.5	0	0
4:03:00	1	85.8	2.1	77	9	5.8	81	1026.5	0	0
4:08:00	1	79.3	1.7	73	8.9	5.7	81	1026.5	0	0
4:13:00	1	78.5	1.4	76	9.1	6	81	1026.6	0	0
4:18:00	1	81.7	1.1	70	9.3	6.2	81	1026.6	0	0
4:23:00	1	82.8	1.3	75	9.4	6.3	81	1026.6	0	0
4:28:00	1	91.9	1.3	74	9.7	6.5	81	1026.6	0	0
4:33:00	1	90.8	1.3	68	10	6.6	80	1026.6	0	0
4:38:00	1	83.7	1.2	87	10	6.7	80	1026.6	0	0

4:43:00	1	77.2	1.7	72	10.1	7	81	1026.6	0	0
4:48:00	1	76.5	1.4	78	10.3	7.1	81	1026.6	0	0
4:53:00	1	69.5	1.8	76	10.1	7	81	1026.6	0	0
4:58:00	1	74	1.6	71	10.2	7.1	81	1026.6	0	0
5:03:00	1	77.1	1.5	70	10.5	7.3	81	1026.6	0	0
5:08:00	1	76	1.8	70	10.5	7.4	81	1026.6	0	0
5:13:00	1	81.4	2.3	65	10.6	7.6	82	1026.6	0	0
5:18:00	1	76.8	1.8	68	10.7	7.7	82	1026.6	0	0
5:23:00	1	85.8	1.9	68	10.9	7.9	82	1026.6	0	0
5:28:00	1	90.2	2.4	67	10.9	7.9	82	1026.7	0	0
5:33:00	1	82	2.7	62	11	7.8	81	1026.6	0	0
5:38:00	1	86	2.3	67	10.9	7.8	81	1026.6	0	0
5:43:00	1	101.5	1.7	78	11.1	8.1	82	1026.6	0	0
5:48:00	1	98.6	2	69	11.1	8.1	82	1026.7	0	0
5:53:00	1	95.3	2.4	69	11.1	8.1	82	1026.6	0	0
5:58:00	1	95.6	2.4	76	11.1	8.1	82	1026.6	0	0
6:03:00	1	100.7	2.4	73	10.9	7.9	82	1026.5	0	0
6:08:00	1	88.1	2.3	66	11	8.2	83	1026.3	0	0
6:13:00	1	101.9	1.7	76	11.1	8.2	83	1026.1	0	0
6:18:00	1	93.3	2.3	67	11	8.2	83	1025.9	0	0
6:23:00	1	102.7	2.2	74	11.1	8.3	83	1025.4	0	0
6:28:00	1	96.4	1.9	86	11.1	8.3	83	1025.2	0	0
6:33:00	1	107.6	2.7	76	11.3	8.4	83	1024.3	0	0
6:38:00	1	99	2.8	75	11.2	8.4	83	688.8	0	0
6:43:00	1	99.7	2.6	80	11.3	8.4	83	515.2	0	0
6:48:00	1	96.9	2.4	72	11.4	8.5	83	527.9	0	0
6:53:00	1	103.3	2.3	84	11.2	8.4	83	607.8	0	0
7:58:00	1	103.4	2.1	83	11.4	8.5	83	996.1	0	0
7:03:00	1	94.8	2.3	85	11.5	8.7	83	1026.4	0	0

Table 3.4.2.11. Speed Log (11-17-04).

	4D			5A			5B			5C			5D					9C					9D					9E				
LN#	1	2	3	1	2	3	1	2	3	1	2	3	1	2	3	4	5	1	2	3	4	5	1	2	3	4	5	1	2	3	4	5
04:48	68	59	59	82	68	55	75	63	55	63	63	51	59	68	46	26	36	FLD	FLD	FLD	FLD	FLD	63	59	48	20	8	55	59	27	51	21
05:03	68	68	51	68	68	55	68	75	59	68	68	59	75	68	59	55	51	41	41	29	6	0	59	55	48	19	30	59	68	29	48	30
05:05	68	63	63	68	75	63	68	55	55	59	63	55	43	46	33	15	23	41	48	26	7	5	55	55	48	20	23	63	82	15	43	20
05:08	75	68	68	82	75	55	63	55	46	63	68	55	63	59	41	16	43	33	51	26	15	13	63	41	20	13	12	48	55	19	37	20
05:14	82	68	55	75	75	75	68	63	63	63	68	59	63	48	26	20	10	46	46	29	24	6	59	55	34	15	15	63	75	16	51	16
05:18	68	68	51	82	82	55	63	55	55	63	68	55	43	41	25	16	13	30	36	34	0	12	59	48	36	21	15	0	75	27	48	29
05:33	75	68	59	68	68	55	68	68	59	22	26	21	46	37	15	19	22	48	55	36	27	25	51	41	37	8	11	48	75	22	55	33
05:35	63	68	63	68	68	59	63	59	55	68	82	51	36	19	10	12	12	41	43	34	15	7	59	5	46	15	17	39	59	16	37	21
05:38	75	68	59	63	68	59	63	59	51	59	63	59	41	43	14	18	41	FLD	FLD	FLD	FLD	FLD	68	51	36	13	10	59	63	19	39	16
05:41	68	68	55	68	68	55	59	55	59	55	68	68	48	51	16	28	41	41	46	32	6	8	46	48	41	17	15	55	63	12	34	6
05:44	68	59	55	75	75	68	75	59	55	34	41	43	43	37	10	10	11	46	48	21	17	15	59	59	55	23	25	48	68	23	46	25
05:47	68	63	59	68	63	59	59	63	59	59	41	63	26	30	12	17	15	32	46	43	22	11	48	51	51	12	21	46	55	15	33	10
05:48	68	63	59	68	63	59	59	63	59	59	41	63	26	30	12	17	15	32	46	43	22	11	48	51	51	12	21	46	55	15	33	10
05:51	63	63	51	63	75	63	75	68	75	51	59	43	51	37	12	16	23	34	39	41	22	19	55	51	34	8	9	59	59	13	39	22
05:53	51	41	41	55	63	41	68	59	43	59	68	51	36	21	11	19	8	41	39	26	8	10	59	48	36	6	0	48	59	12	46	0
05:56	68	59	55	63	68	63	75	63	55	63	68	59	37	36	0	11	0	41	39	34	16	17	48	29	34	11	17	51	63	10	43	10
05:59	68	59	55	75	68	75	68	68	55	63	68	63	75	##	41	8	12	48	37	23	14	16	51	51	41	20	23	63	59	17	43	17
06:01	FLD	FLD	FLD	59	59	51	75	59	48	59	68	48	55	82	51	21	48	55	55	33	7	4	59	46	36	23	23	59	55	9	37	12

06:03	FLD	FLD	FLD	59	59	51	75	59	48	59	68	48	55	82	51	21	48	55	55	33	7	4	59	46	36	23	23	59	55	9	37	12
06:05	63	68	59	68	63	51	68	68	48	63	63	51	68	63	8	0	15	37	43	28	10	19	63	51	43	17	20	55	82	11	59	15
06:08	75	59	59	68	63	55	63	59	46	63	63	63	48	39	11	11	14	48	46	41	13	11	63	59	55	13	22	51	63	19	39	20
06:11	63	63	55	59	63	59	68	63	51	63	68	51	68	55	51	23	27	28	41	23	13	6	55	55	39	33	32	48	59	7	46	10
06:14	68	63	55	63	55	55	FLD	FLD	FLD	63	68	55	68	63	24	22	21	36	48	34	12	14	55	51	41	22	20	51	68	16	41	17
06:18	63	55	41	63	63	75	75	63	48	68	55	43	68	51	29	10	33	37	46	26	16	26	59	48	36	22	26	41	59	15	39	6
06:20	68	68	63	68	75	63	82	59	51	68	63	63	63	63	39	43	48	48	48	28	16	18	59	0	48	11	12	30	43	18	7	22
06:26	75	63	59	68	68	63	68	59	55	63	59	55	46	0	11	8	10	36	43	28	25	25	55	51	41	26	12	29	51	9	0	15
06:31	68	63	55	68	68	63	63	55	48	63	63	55	75	75	55	30	41	48	48	37	27	22	51	7	30	17	15	19	28	22	10	7
06:33	68	63	55	68	68	63	63	55	48	63	63	55	75	75	55	30	41	48	48	37	27	22	51	7	30	17	15	19	28	22	10	7
06:35	59	48	43	55	59	46	59	63	48	59	68	55	63	63	51	59	51	63	48	48	26	11	51	39	29	11	12	16	33	22	16	20
06:38	68	75	55	63	75	63	68	59	55	59	55	33	55	43	15	18	30	FLD	FLD	FLD	FLD	FLD	63	59	41	16	15	22	9	15	13	0
06:41	63	63	59	51	68	15	63	59	48	63	63	55	63	68	55	55	55	41	55	37	5	0	55	63	48	15	7	51	59	26	27	20
06:48	63	63	55	68	63	59	75	59	59	FLD	FLD	FLD	82	68	48	68	63	26	34	17	8	17	55	36	29	20	5	22	27	14	7	8
06:53	68	63	55	75	68	63	63	51	46	63	68	59	82	68	48	63	59	63	55	39	20	23	68	75	43	19	13	15	16	30	11	32
06:56	68	68	63	68	75	82	75	75	55	59	68	51	75	63	55	63	68	55	51	39	12	29	51	48	34	21	24	0	25	26	6	25
06:59	68	63	51	75	68	43	68	59	59	63	59	59	68	75	59	59	63	55	63	41	7	10	63	59	30	20	22	12	23	27	26	17
07:02	75	82	82	75	68	68	68	59	63	FLD	FLD	FLD	82	68	59	68	63	55	48	22	13	21	59	51	36	12	0	16	39	20	17	17
07:03	75	82	82	75	68	68	68	59	63	FLD	FLD	FLD	82	68	59	68	63	55	48	22	13	21	59	51	36	12	0	16	39	20	17	17
07:18	75	59	55	75	63	59	75	63	59	75	63	68	75	82	82	59	63	68	82	75	59	59	82	82	68	51	63	63	91	68	55	68

3.5 Analysis of CAWS Software

Motivated by observations of a number of unexpected behaviors by the CAWS system, we requested and were permitted access to the Signview and TMS software source code, under a non-disclosure agreement required by Caltrans to preserve the potential for commercialization of these as products.

Both the TMS and the Signview/CAWS programs are complex developments with an impressive array of features. Although automated warning and dynamic speed limit systems are more common in Europe, they are relatively rare in the USA. The development effort behind the CAWS, embodied in the Signview/CAWS, TMS and QCMS programs, represent one of the first efforts in the USA to implement a fully automated driver warning system for both traffic and a range of weather conditions. The fact that the Signview/CAWS and TMS programs were developed entirely by a team of only three software engineers in Caltrans Operations, without prior experience from similar systems, and made fully operational in a very short period of time, is a credit to the agency and the competence of the designers and programmers. Problems with any large software work are inevitable. Commercially developed software is usually subjected to extensive testing by a separate group tasked with finding bugs or design problems. This is usually followed by an extensive beta test period in which the program is in the hands of a limited number of end-users cooperating with the final de-bugging of the program and application. Time and resources did not permit any such test procedure for the CAWS software. It is therefore not surprising that a number of bugs and critical design issues were found in our detailed analysis.

No formal documentation was available for either the TMS or Signview/CAWS software. An operator’s manual accompanied the original version of the Signview software, but no operator’s manual or other

operational documentation were created for Signview/CAWS. Since the modifications to the program were radical, the original Signview manual was of little or no value to understanding the control strategy or troubleshooting the CAWS system. A minor update to the Signview/CAWS software occurred in September 1997, also without documentation. It is unclear what direction was given to the system operators in the use and maintenance of the system. These limitations appear to be due to a lack of resources allocated to the project and possibly a lack of agency experience in large complex software development projects.

This section presents our analysis of the source code design, which also reveals the control strategy of the CAWS in support of our efforts to explain some of the unusual system behaviors revealed from the system logs and our direct observations.

3.5.1 Traffic Monitoring System (TMS)

Source code for the TMS program and Signview 3.11 program was provided by Joel Retanan of Caltrans Research and Innovation Division, formerly of the Electrical Section of HQ Traffic Operations. His cooperation and assistance was vital to the success of our evaluation efforts. We only report below issues we have discovered in the TMS program which helped to explain unexpected system responses described in the previous subsection. The reader is therefore cautioned to not be misled by the problem-finding tone of this report section. The overall program, under normal conditions, functions consistent with specifications and reliably (not withstanding the control strategy issues described herein which were not software errors).

3.5.1.1 Program Overview

The TMS program communicates with 36 speed monitoring stations via multi-drop modems over leased lines. The standard star network topology deployed by Caltrans for field traffic monitoring in all jurisdictions was used. Direct dedicated phone connections are provided to six Field Master systems (each a Type 170 controller), each connected to six monitoring stations, including itself. The TMS software periodically polls the field masters, which propagate the polling requests to the other field units. The serial communications rate is 1200 bps (bits per second). The TMS software also transmits alarm decisions to the Signview computer located physically next to it in the District 10 Traffic Management Center. Signview is then responsible for generating appropriate message responses, and displaying these on the proper messages to the CMSs.

In all tables to follow, the displayed data are color coded for ease of interpretation of the traffic conditions. Green, yellow, and red indicate speed flows of above 35 mph (no message), below 35 mph (slow traffic), and below 11 mph (stopped traffic), respectively. The units for speed, lane volume, and site volume are miles per hour, vehicles per hour per lane, and vehicles per hour, respectively.

Data from each speed site is received by the TMS at 50-second polling intervals. The speed and volume data reported for each polling period by the speed monitoring stations are processed by the TMS software and used to generate a condition or alarm level for each speed station, which is passed to Signview to determine, if appropriate, a warning message for a each CMS from a catalog of possible “canned” warning messages. The per-lane traffic data from each site generates an internal “speed condition flag” based on an algorithm which considers per-lanes speeds, and validates these against per-lane volumes. The three possible speed condition flag levels and a description of their associated conditions are shown in Table 3.5.1.1.

Table 3.5.1.1. Speed Condition Numbers and Associated Conditions.

Flag Value	Condition	Description
0	Normal	At least one lane at site registers speed value \geq 50mph
1	Slow	Minimum speed for any lanes \leq 35mph (with no lane \geq 50mph)
2	Stopped	Minimum speed for any lanes \leq 11mph (with no lane \geq 50mph)

The algorithm that generates the speed condition flag implements the following logic tree:

If any lane (among up to five lanes) at that site indicates a speed \geq 50 mph, the TMS assigns a normal traffic condition flag value = 0.

If no lane indicates a speed of \geq 50mph, the minimum speed from all the lanes at is site is used to determine the speed condition flag:

If the minimum speed is \leq 35mph, the TMS assigns flag = 1.

If the minimum speed is \leq 11mph, the TMS assigns a stopped traffic condition flag = 2.

A form of data filtering is implemented, probably to help reject potentially erroneous readings that occur in only one of the 50-second polling cycles. Flag values from the current and the two prior pollings of a speed monitoring station are summed and this result is passed to Signview to determine if and what message will be displayed on each CMS. The possible results and interpretations are shown in Table 3.5.1.2, based on comments in the code. The total of the three pollings can range from 0 to 6. Messages are generated for sums 3 through 6, which are inferred to correspond to slow or stopped traffic. Only the sums are transmitted to Signview, one sum for each CMS.

Table 3.5.1.2. Speed Flag Sum and Inferred Traffic Condition.

Speed Sum	Resulting Condition	Comment
0-2	Normal	At least one normal condition result
3	slow traffic	three slow traffic condition results
4-6	stopped traffic	At least one stopped traffic condition result

According to in-code comments, Signview maps flag sum values from each speed monitoring site to at least two for possible action. It interprets the flag sums as follows:

Flag sum 0-2 => no warning message

Flag sum 3 => "SLOW TRAFFIC AHEAD, CAUTION" preceded by "HIGHWAY ADVISORY AHEAD"

Flag sum 4-6 => "STOPPED TRAFFIC AHEAD, CAUTION" preceded by "HIGHWAY ADVISORY AHEAD"

(Level 4 was originally programmed to display the "SLOW TRAFFIC.." message. It was discovered later that flag sum 4 actually actuates a "STOPPED TRAFFIC" message due to a change in the CMS bulb map graphics file, to be discussed later.)

This summation algorithm implements a simple form of data validity checking, which prevents the activation of a warning message based on data from a single polling of a site. However, it introduces a lag in response to an evolving traffic incident, since the resulting traffic disruption must be registered during three successive polling cycles, each 50 seconds in duration, introducing a total lag of 2.5 minutes for the detection event to be recognized. This lag is not accounted for in the CAWS reaction delay due to the polling cycles, as previously discussed.

Format of message packet reported by 170 controller when polled every 50 seconds by TMS:

COMM.C::void RequestMasterData(uchar mstr) :

To request traffic data from a master, TMS software sends the following RS232 packet (of bytes)...

Message#4	Complementof4	MasterIDNumber	Report#4	MSBmemoryLoc	LSBmemoryLoc	Checksum
0x04	0xFB	0x__	0x04	0x00	0x00	0x__
	+	+	+	+	+	
CHECKSUM						/ [Checksum % 256]

The following is from the TMS software and not confirmed from the 170 Controller code. The field master will send the traffic data from up to five local 170s. Actually, the packet can accommodate up to six total speed sites (Master plus five slaves.) The received data packet contains 147 bytes, arranged as follows:

byte 1: 123 = number of bytes to receive

byte 2: 132 = 8-bit complement of byte 1

bytes 3-8: Lanes 1-6 speeds of Master

bytes 9-26: Lanes 1-6 occs & vols of Master (occ=2 bytes, vol=1 byte)

bytes 27-32: Lanes 1-6 speeds of Local 1

bytes 33-50: Lanes 1-6 occs & vols of Local 1

bytes 51-56: Lanes 1-6 speeds of Local 2
bytes 57-74: Lanes 1-6 occs & vols of Local 2
bytes 75-80: Lanes 1-6 speeds of Local 3
bytes 81-98: Lanes 1-6 occs & vols of Local 3
bytes 99-104: Lanes 1-6 speeds of Local 4
bytes 105-122: Lanes 1-6 occs & vols of Local 4
bytes 123-128: Lanes 1-6 speeds of Local 4
bytes 129-146: Lanes 1-6 occs & vols of Local 4
byte 147: 8-bit checksum

There are six Master computers. Each Master computer has six sites associated with it. Each site has six lanes associated with it. Each lane has Speed[1] Occupancy[2] Volume[1] for a total of 4 bytes each and 24 bytes of data per site.

Note: GUI sets error flag `err_speed = 1` for `speed > 150`

GUI sets error flag `above_35 = 0` for `speed <= 35`

GUI sets error flag `err_vol = 1` for `volume = 0`

GUI sets error flag `err_occ = 1` for `occupancy = 0`

If `err_speed` is set, GUI shows (err) for Avg speed, Avg Occ, Avg Vol

If `(err_vol || err_occ) && !above_35`, GUI sets color to light gray.

Since occupancy can be set to 0 by accident, low speed conditions will light the speed station box gray (not RED or some indication of a traffic jam).

The following subsections identify specific implementation issues in the TMS software or related speed measurement hardware that were found in our analysis to be problematic.

3.5.1.2 Warning Condition Persistence for CMS Activations

The TMS does not send a warning message to the Signview when at least one of the three immediately prior pollings of a site indicates a '0' alarm flag (normal condition or error). The speed data example shown in Table 3.5.1.3 highlights a case where a single normal condition nullifies two warning conditions.

Table 3.5.1.3: Example Polling of Speed Data

Time	Lane 1	Lane 2	Lane 3	Lane 4	Lane 5	Condition (num)
11:10:10	28	13	28	5	8	stopped (1)
11:11:00	15	130	25	8	7	normal (0)
11:11:50	10	13	20	5	9	stopped (1)
11:12:40	20	240	21	5	8	normal (0)

In the example shown in Table 3.5.1.3, since there is a speed value ≥ 50 mph in the second line of speed data, no message would be sent to Signview. This approach in essence requires that any non-normal condition be present for at least three polling cycles (50 seconds each) before the associated message is displayed. The worst-case analysis using this approach is that nearly four polling cycles would be required to display a warning message in if a speed event occurred immediately follow a polling cycle.

Note that 0 mph speed is not invalidated in the code as we see '0' in the log files because when there is no traffic for 50+ seconds the 170 calculate does not send anything to the TMS software. The reason for this is that the speed map data is initialized to all 0xFF in the TMS software before polling begins of the field sites.

Therefore if the field sites send 0x00 it would be considered 0 mph by TMS software and (in conjunction with other lanes) could cause Signview to issue a stopped traffic message.

3.5.1.3 Logging Interval

This issue only affects the usefulness of the TMS speed log files when used to reconstruct logged events.

TMS software also stores the traffic lane speeds if it receives data indicating either slow or stopped traffic events corresponding to speed condition sum 3-6. Because Signview polls every 3 minutes, the data logging frequency can increase to once every 3 minutes. The TMS software already automatically logs data every 15 minutes. Each 15-minute dump is timer driven and is the latest polling cycle data (not averaged in TMS).

The actual code that does this is

```
void ConvertLog( void ) (LOG.C 723)
```

Data gets written to the speed TXT log file as "err" if speed > 150 mph

The automatic conversion to a shorter polling interval is tied to the TMS program's generation of alarm levels that tell the Signview program to generate traffic advisory messages. If these alarm levels are not generated, the logging interval remains 15 minutes. In cases where the TMS failed to properly actuate a message-worthy alarm, the lack of information between the 15-minute log entries makes it difficult to understand the actual events at that time.

3.5.1.4 Data Communication Error Assignment

The TMS program implements a transmission latency check for communications from any of the field masters (network star hubs). If more than 1.5 seconds elapses between received bytes, 0xF0 (hexadecimal F0 = decimal 240) is assigned to speed, occupancy, and volume data values. Communication errors from speed monitoring stations will result in the speed, occupancy, and volume being set to a decimal value of 240. Since a lane speed reading of 240 mph is over 50 mph, the threshold which results in an alarm flag number of 0 for that site, it inhibits the generation of a CMS message and is interpreted as a normal traffic condition. This is an efficient and clever way of combining a traffic condition test with a communications error test. However, it makes the system acutely susceptible to single or intermittent communication errors for any lane at any site. Such errors are not infrequent with loop detectors. And due to the three-cycle alarm flag summation requirement for message activation, this can affect valid activation of a CMS until three successive successful pollings have elapsed. For example, the communications sequence of Table 3.5.1.4 would result in no message at 1:50:50 in the middle of a stopped traffic condition, and reduce the warning level at 1:51:40:

Table 3.5.1.4. Communications Sequence Causing Potentially Incorrect Traffic Warnings.

Time	Condition	Comment	Current alarm flag	Alarm flag sum	Signview message
1:50:00	Stopped Traffic	speed near 0; no error	1	4	STOPPED TRAFFIC
1:50:50	Stopped traffic but communication error	speed set to 240	0	2	(blank)
1:51:40	Stopped Traffic	speed near 0; no error	2	3	SLOW TRAFFIC

With centralized control via the Signview computer, a more sophisticated method of handling and validating communications errors may have been possible.

3.5.1.5 System hang-up due to communications errors

The TMS log files contain a number of times in which no entries were made for periods of time, indicating the system stopped functioning. This usually occurred after a period in which communications errors had been logged. Normally, the TMS software logs communications errors as "COM" entries in the log, but continues to operate until communications are restored. In the cases were concerned with, the system stopped logging entries of any kind, indicating that the system was either shut off or had hung up. The system recovery time has varied from 45 minutes to several days. Since many of these times were in the middle of traffic or weather events, or were in the early hours of the morning, it was unlikely that these were deliberate system shutdowns by TMC operators. For example:

On March 01, 2005 0000 there was a field communication error for site 1A reported in the TMS logs until 1315. During the field communication errors the following 15-minute intervals were not logged:

0245, 0600, 0915, 1030, 1045, 1115, 1300

On March 1, 2005 1315, a system-wide communications error was logged by the TMS program until March 10, 2005 0000. On March 1, 2005 the following 15-minute intervals were not logged:

1400, 1415, 1430, 1600, 1700, 1730, 1815, 1830, 1900, 1915, 1945, 2000, 2115, 2215, 2315, 2330

Since TMS is programmed to make a log entry every 15 minutes unless a traffic event is occurring, which at that time will log every 3 minutes, there should be greater than 96 log entries for any given day under normal operation. During the system-wide communication error the following log entries were recorded:

Date	Log Entries
March 01, 2005	75
March 02, 2005	42
March 03, 2005	34
March 04, 2005	3
March 05, 2005	0
March 06, 2005	0
March 07, 2005	40
March 08, 2005	71
March 09, 2005	61
March 10, 2005	91

On March 03, 2005 the last log entry was made at 1630. Another log entry wasn't made until March 04, 2005 0845 and continued to log system-wide communication errors until 0915. The TMS software did not make log entries until March 07, 2005 1100. We inquired with staff at Caltrans D10 about this anomaly in the TMS logs, amounting to a nearly three-day outage. The response we received indicated that the system operators assumed that the system was supposed to stop logging entries when external communications problems occurred. They confirmed that the system had not been manually shutdown during this period, but that the "speed monitoring computer was not collecting data."

The problem was not external communications, since if this was the case, the TMS program would have logged a communications error every 15 minutes. This was a problem with the TMS program or computer.

The TMS software only communicates with two systems, the Signview computer and the field masters. We found no problems in the code for communications with the Signview program, other than a failure on the Signview side to handle loss of communications with TMS (see subsection 3.5.1.8). But we found a number of problems in the communication protocol between TMS and the field masters.

If there is a loss of communications between any of the five field masters and TMS computer, the TMS program would timeout, attempt two more times to reach the unit, then log a COM error (by reporting decimal 240 mph for that site), and move onto polling the next field unit or wait to start the next 15-minute polling period. The TMS communications code includes multiple error checking tests intended to assure

that only valid field data was accepted and acted upon. However, the implementation of these tests in the code created a number of ways that could potentially hang up the program or leave the program in an unstable state.

As discussed above, the TMS software communicates with field controllers on a byte-by-byte basis, using packets 147 bytes in length. The first two bytes are, respectively, the total byte count of the packet and the complement of this byte count. The following 144 bytes are the data payload. The final (147th) byte is a checksum byte. Each of the 144 payload (data) bytes are assigned successive positions in a fixed array (buffer). There is no buffer overrun test done – if more than 144 bytes are read into the array, the memory bytes immediately above the array in memory are overwritten. It is unknown how the compiler assigned fixed memory locations, but it is expected that other system variables reside at locations above this array. The ramifications of overwriting over system variables could be benign, but could be as severe as to cause the system to enter test mode (if a particular bit is overwritten) in which it synthesizes its own traffic data, unknown to the system operators, but appears to continue to function normally. Usually, the result is a hung system. (We should note that susceptibility to buffer overrun is a common type of programming oversight, which for perspective, has been exploited by hackers attempting to gain unauthorized access to Microsoft operating systems over the Internet.) Can a buffer overrun occur in this case? Yes, in fact, quite easily, as explained below.

Bytes are received in a continuous “while loop” that terminates only when specific conditions are met (or not met). Inside this loop, the second byte is tested against the first to verify that they are indeed complements. If this test fails, the packet byte counter is reset to zero, and the next two received bytes are tested again the same way, assuming that the prior two bytes were not really the start of a packet. The test is repeated continuously until a 1.5 second timeout occurs, presumably at the end of the present 147-byte packet. Since both the first and second bytes are discarded, a falsely detected first byte could block the recognition of a valid packet that followed it.

Assuming that this first test is satisfied, the TMC program expects to receive the 145 more bytes in a presumed valid packet. It continues to accept bytes until one of two things occurs that could terminate the while loop: either a valid checksum byte is received as the 147th byte in the stream, or 1.5 seconds elapses since the last byte was received. In the absence of either event, the TMS program remains locked in a “while loop” accepting incoming bytes. This apparently presumed that a 1.5 second minimum time gap would always follow each 147-byte packet. If the 147th byte is confirmed to be a valid checksum, the 144-byte data array is processed.

However, if the checksum is invalid, and bytes (or noise) continue to be received without a 1.5 second gap, the program continues to accept the “data” into the growing array without bound, until either a 1.5 second gap occurs or the system hangs due to overwriting of other variables above the array.

Even if the erroneous communications stream eventually stops, the damage due to the buffer overrun could leave the system unstable. What would cause more than 147 bytes to be received without a 1.5

second gap? This can happen due to an error in the transmission routine on the 170 side, but is more likely due to a problem with any of the communications components in the signal path, or the telcos leased lines, causing a stream of noise which is detected by the ACIA in the TMS computer as a continuous stream of bytes. In this situation, the TMS program would remain locked in the receive loop, and would appear to hang up.

We expect that noise was common on the CAWS leased communications lines. In the course of setting up our field sites, we noted that phone lines installed at both the Mathews Road cabinet and the CMS site cabinet had floating grounds, which resulted in levels of communications noise so great that our V.32BIS modems would sporadically drop communications or refuse to connect. We eventually abandoned the use of copper leased lines in favor of far more reliable CDPD modems communications, although we retained these lines as an automatic backup communications option at sites where they were available (they were never used).

Reference: TMS program module COMM.C starting at line 775. The 147th byte checksum is calculated starting on line 807. Source code is not included in the Appendix due the non-disclosure agreement, but will be provided with written permission of Caltrans Division of Traffic Operations.

3.5.1.6 Field Master Name Hardcoding

Field master names / values are hard-coded in the TMS software, via the following string (in TMS module COMM.C line 915):

```
char *master_name[]={ "2A", "3B", "5A", "9B", "8B", "7A" };
```

The "STATIONS.TXT" configuration file was believed by the system operators to be used by the TMS program to indicate what speed monitoring sites are attached to the system and which sites were designated "field master" sites. According to this file, the following sites are considered field masters: 2A, 3B, 5A, 9B, 8B, 7A.

However, the "STATIONS.TXT" file is not actually used by the TMS software. The software comments reference this file but the program does not read any configuration data from it; site names and site locations are instead hard-coded into other portions the TMS software (module MAIN.C line 1089).

This is not a performance limitation of the TMS code, but is pointed out because it appears the original design intention was to use this configuration file, but at the time the program was delivered, the same information had been hard-coded in the source code, probably for development purposes. The hard-coding of this information prevents the portability of the program for any other deployment, or the reconfiguration or expansion of the communications network without recompiling the code. The existing CAWS deployment was actually only the first phase of a proposed larger project, which would more than double the number of speed monitoring sites. The added flexibility might have been useful if the expansion of any communications network changes had been required.

3.5.1.7 Speed Data Qualification

This is not a software error, but a potentially problematic aspect of the control strategy implemented in the code (reference module COMM.C starting at line 1074) that has been mentioned in several of the previous case histories. The TMS software implements a form of speed data qualification that does not adequately consider multi-lane traffic in merge zones where large lane speed gradients are normal. The algorithm checks if any lanes speed at a site is greater than 50 mph, and if true, it forces an alarm flag value of 0, regardless of the speeds reported in any other lanes. This inhibits the generation of alarm codes 1 or 2 that could indicate a slow or stopped condition in some of the lanes. This approach is probably based on the philosophy that if any lane at a monitoring site is in free flow, then a slow or stopped condition in the other lanes is not sufficient to report the site overall site condition as slow or stopped. It may also rely on the assumption that higher speeds are reported more reliably than slower or zero speeds for the inductive loop detectors.

This approach seems reasonable for sites at which all lanes are through lanes, or lanes subject to queues are treated separately. However, as noted previously, this approach is flawed in the 5-lane merge section of the Mossdale Y, a known area of high accident rates. Figure 3.5.1.1 shows an image of the WB SR-120 merge zone I-5 SB taken by a network camera we placed at the weather station 9 near the Mossdale Y to better understand the concentration of accidents in this area. Lanes 4 and 5 are the rightmost lanes in the image. Lanes 4 and 5 provide a merge zone both for traffic transitioning from WB SR-120 onto SB I-5, and for traffic converging from I-5 and SR-120 onto WB SR-205. These lanes are frequently subject to slow or stopped traffic, while lanes 1, 2 and 3 are through lanes on SB I-5. The lane speed gradient is particularly severe at the end of this 0.5-mile merge zone, where lanes 4 and 5 transition onto SR-205. SR-205 is subject to recurrent congestion during commute hours, which backs up traffic into the merge zone. Figure 3.5.1.2 shows a diagram of a typical lane speed gradient at the SR-205 connector.

Speed monitoring sites 9B, C, D and E are located in this critical merge zone and are intended to activate the CMSs on I-5 and SR-120 just prior to the Y. The above 50 mph speeds in lanes 1, 2 or 3 inhibit these sites from reporting alarm levels other than 0 due to this logic. Once traffic backs up all the way onto the SR-120 transition road before the merge, speed monitoring sites 5A and B detect the slowed or stopped traffic and can activate CMS 9 to warn traffic entering from 120 (only). However, this is too late: traffic entering the Y can see no warning of slow or stopped traffic as little as 0.2 miles ahead. This is particularly important for traffic entering from 120 since the transition road enters the Y through a left turn under a railroad trestle with limited sight distance. The proximity of the Mossdale landing and waterway also makes this location particularly prone to fog, which further reduces sight distance, especially during morning commute hours during the fog season. While the road geometry and natural environmental conditions are primarily responsible for the elevated accident risk at this location, correction of the control strategy for this special situation could result in a more effective warning, and encourage greater driver confidence in the CAWS system.



Figure 3.5.1.1. WB SR-120 Merge to SB I-5 at Mossdale Y.

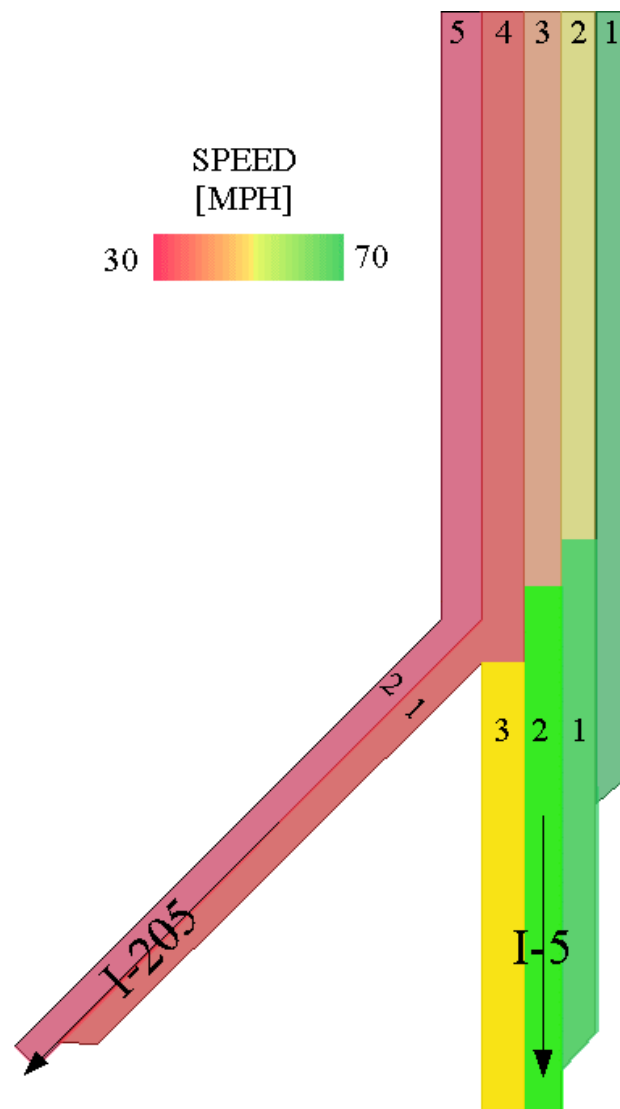

Figure 3.5.1.2. I-5 to I-205 Traffic Pattern.

3.5.1.8 TMS to Signview Communications

The TMS program is responsible for communicating alarm flag sums to the Signview program as the primary information for speed warning activations of CMSs. The TMS only sends messages to Signview when warning conditions are present (slow or stopped traffic). These are sent asynchronously, that is, not on a polled cycle, although Signview implements its own polling schedule for processing these messages and those sent from the QCMS computer. Under this communications model, Signview assumes that if no data is sent by the TMS computer, that no CMS activation is required for that site. This is a reasonable failsafe approach in the event of loss of communications between the TMS computer and the Signview computer. However, other than an indication of the TMS system console, there is no provision for recognizing and urgently acting upon a loss of communications. Comparisons of TMS Signview logs indicate several periods from hours to several during which communications was out, sometimes to one or more TMS field masters or the QCMS system. Such outages were usually the

responsibility of the leased line provider, which usually would correct the problem only after being informed of the problem by District personnel. It would have been advantageous in this application to have the TMS or Signview program automatically notify District personnel, for example, via an audible alarm sound from the computer, or an automatic cell phone paging service. A more rapid response to such situations would encourage greater driver confidence in the CAWS.

3.5.1.9 Inconsistent Use of Global Program Constants

The TMS.H header file contains several global constants that can be accessed throughout the TMS software. Several of these constants are shown in Table 3.5.1.5.

Table 3.5.1.5. Selected Constants in TMS Software.

Name	Value	Description
POLL_CYCLE	50	duration (in seconds) used by TMS software to poll 170 controllers
NUM_LANES	6	number of lanes
NUM_STATIONS	36	number of stations
STOPPED_TRAFFIC	11	maximum value used for stopped traffic declaration
SLOW_TRAFFIC	35	maximum value used for slow traffic declaration

Defining constants in this manner was consistent with good programming practice. Using these constants in the associated source code increases the robustness of software package. However, the TMS software contains many instances where these constants should have been used but were not. This is particularly true for the NUM_LANES and NUM_STATIONS constants, and less frequently for the STOPPED_TRAFFIC and SLOW_TRAFFIC constants. In addition, there are many FOR loops and other statements that should be using these constants but do not. Any changes made to these constants in the TMS.H files requires that the TMS software to be recompiled in order for the changes to take effect.

Code reference: COMM.C line 942, MAIN.C line 675.

This has no effect on the operation of the TMS software, but limited portability, ease of problem diagnosis, and expandability.

3.5.1.10 Contradictory CMS Bulb Map Indexing

The “Bulb Map” is the graphical layout of the actual messages displayed the CMS in response to a message decision action by Signview. It is contained in the program file MESSAGE.LIB. The sum of speed alarm flags from the most recent pollings of a speed station determine which message will be display on a particular CMS. As described previously, an alarm flag sum of 3 should result in a “slow traffic” message while summation of 4-6 should result in a “stopped traffic” message. However, the current content of the message bulb map displays “Slow traffic ahead” when the flag sum equals 4. A sum of 4 should display a “Stopped traffic ahead” condition. It is possible that this change was the

results of a patched correction to the control strategy, which changed alarm sum level 4 to a “slow traffic” rather than a “stopped traffic” condition. However, this is inconsistent in the TMS and Signview code.

3.5.1.11 Improper Data Conversions

Programs that transfer numerical data over a communications link will typically transmit data a byte at a time, thus representing and storing 16-bit numbers as two separate 8-bit values. The receiving program converts the two successive bytes into a single 16-bit value. The common approach is to multiply the most significant byte by 256 (left shift by 8 bits) and add the least significant byte. The result is generally stored as a 16-bit unsigned integer that is then treated as a single value. The code to perform this conversion in the TMS software (COMM.C 849-850) is listed below (variable names have been simplified for this example but accurately represent the associated code in the TMS software):

```
occupancy = (unsigned)[bytelocation] * 256;  
occupancy += (unsigned)[bytelocation + 1] / 18;
```

With ‘C’ order of operations, this code simplifies to the following:

```
occupancy = ((unsigned)[bytelocation] * 256) + ((unsigned)[bytelocation + 1] / 18);
```

In all likelihood, the developers of the TMS software most likely intended to perform the operation listed by the following code:

```
occupancy = ((unsigned)[bytelocation] * 256 + (unsigned)[bytelocation + 1]) / 18;
```

intending to scale the entire 16-bit number by a division by 18, rather than just the lower byte. The scaling by 18 probably mirrors the scaling performed in the 170 controller code (which we did not have access to) which created the need for a 16-bit representation of Occupancy. In any case, the separate division of the low byte by anything would make the re-assembly of the 16-bit value received by the TMS incorrect.

Also related to this potential error is the following situation. Immediately following the code described above, a check is performed on the final 16-bit value (COMM.C 851-852). If this integer value is greater than decimal 100, the occupancy is set to 0 (most likely as a method of indicating an error). But any time the most significant byte is non-zero, the value computes to a value over decimal 100. This value is then set to zero in the final check.

Why doesn't this seem to affect the actual control, invalidating all speed data reported from the field stations? In subsection 3.5.1.12 below, we discovered that the use of occupancy information is ignored due to a separate coding error. This may be a case where two software bugs cancel each other out.

3.5.1.12 Speed Validation Criteria

The TMS source code contains the following comment (in COMM.C line 1056): “Speed is only valid if volume or occupancy is non-zero, which is a case when a loop or sensor is bad”. The source code associated with this comment (COMM.C line 1072) is listed below:

```
if( (ptraf->volume[lane]!=0) && (ptraf->volume[lane]!=0) )
```

The second use of the ‘volume’ variable appears to be an error, which limits the validity check to volume only. The line of code probably was intended to read as follows:

```
if( (ptraf->volume[lane]!=0) && (ptraf->occupancy[lane]!=0) )
```

A check of both volume and occupancy was clearly intended and would seem appropriate. The current TMS code ignores the intended occupancy check for validation of the speed data reported in each lane.

3.5.1.13 Lack of Pre-Incident Data Logging

The TMS software does not log information about the occupancy or volume data that it receives from the 170 controllers. The TMS software logs speed data only every 15 minutes when there is not a traffic-related CMS activation, and more frequently when there is. For traffic analysis or evaluation purposes, it would be immensely valuable to know traffic data (volume and occupancy as well as speed) during the period immediately preceding the critical event. If the TMS software maintained in memory the past several 50-second polling records, and logged this data in greater detail in the event of an activation, examination of the logs may reveal useful information on the traffic condition precursors to the incident.

3.5.2 **Signview/CAWS**

3.5.2.1 Response to visibility alarms – failure to display message for level 3

Reference: SS 3.3.3.1, fog activation event Dec. 2 2003. Also, all events in which visibility fell below 100 feet.

In data transmitted to Signview, the QCMS computer sends two bytes of information per weather station: the first byte contains the weather station number and the second byte contains an alarm flag status. The alarm flag byte is referred to as the “FOG DAT” or “WS FLAGS” byte inside Signview. The mapping of alarm codes to byte values is shown in Figure 3.5.2.1. The format of the alarm flag byte is further explained in shown in Figure 3.5.2.2. Only the two least significant bits are read by Signview for messages activation purposes.

These bits determine the three possible alarm code levels used by Signview to determine a fog warning message. The thresholds for each alarm level are configured via the user interface on the QCMS

computer. However, the mapping between the alarm level and the appropriate fog warning message is established by Signview. A configuration file allows the assignment of messages to alarm levels one and two. Alarm level three is not handled by Signview. In Signview source code module SV12A.c starting at line 675, a hard-coded blank message is assigned for visibility level 3. This cannot be change without modification of the source code and re-compiling. This causes the blanking of the CMS when visibility falls below 100 feet that we observed during all serious fog activation events. This was apparently an oversight in the code that should be corrected.

Following our preliminary report and recommendations for immediate corrections in April 2004, District personnel devised a resourceful fix to this problem. Since recompiling the Signview source code was not an option, they reset the threshold for alarm level three on the QCMS computer to zero feet. This would leave alarm level two active all the way down to zero feet, and alarm level three would never be activated.

Caltrans Meteorological System

Contract No. 10-442204

		ALARMS								
		VISIBILITY (FOG)			VISIBILITY (NO FOG)			WIND	RAIN	TEMP.
		LEVEL 1	LEVEL 2	LEVEL 3	LEVEL 1	LEVEL 2	LEVEL 3	ALARM	ALARM	ALARM
FIRST CHARACTER	1								X	
	2									X
	3								X	X
	4	RESERVED								
	5									
	6									
	7									
	8									
	9									
	A									
	B									
	C									
	D									
	E									
	F									
	SECOND CHARACTER	1	X							
2			X							
3				X						
4										
5					X					
6						X				
7							X			
8								X		
9		X							X	
A			X						X	
B				X					X	
C									X	
D					X				X	
E						X			X	
F							X		X	

Table 2
Master Computer Data Byte

Figure 3.5.2.1. Decoding of alarm levels from QCMS master computer data byte. From QCMS User's Manual.

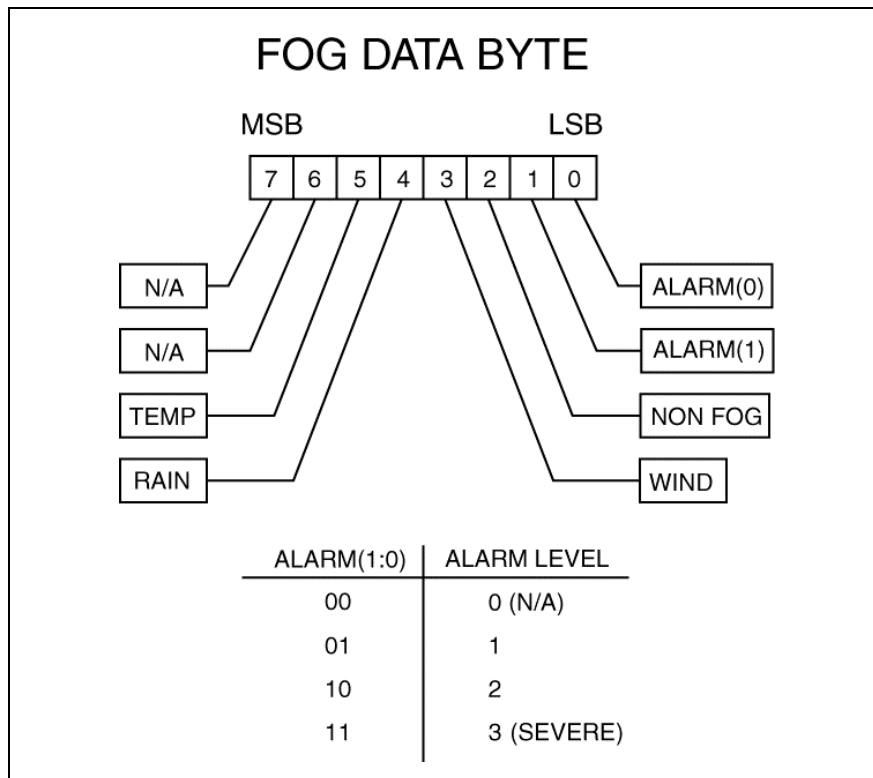

Figure 3.5.2.2. Fog level alarm byte bit definitions.

3.5.2.2 Inability to alert for fog without RH sensor, or to detect failure of RH sensor

Reference: SS 3.3.3.1, 3.3.3.3, 3.3.3.4, 3.3.3.5, 3.3.3.6 fog activation events 2003 through 2004, and Qualimetrics Caltrans Meteorological System User’s Manual, J54214-001. pg. 16).

With reference again to Figure 3.5.2.1, Signview recognizes only second byte values hex values 1, 2 or 3 (not 4 through F) as valid fog alarm levels. These codes are generated on when both visibility thresholds are exceeded, and when relative humidity is detected over 75%. Second byte values 5,6,7,D,E, or F correspond to basic visibility thresholds. They are not triggered if RH < 75%. This causes the CAWS to ignore poor visibility caused by sources other than water fog, for example, dust or smoke which are prevalent in the CAWS area. It also cannot respond to poor visibility if the RH temperature/RH sensor has failed, which we observed to occur several times during our two-year driver behavior study. Apparently, the RH sensor is a relatively high failure rate and instrument that is very expensive to replace. Unfortunately, District personnel were unaware of the distinction that Signview was making between fog and visibility because of this decoding strategy. They were therefore not aware that the RH sensor was a vital instrument for the activation of fog warnings by the CAWS, and these instruments were not among the highest service priorities. In most of the fog activation cases cited above, fog messages were not activated because of input, correct or missing, from the RH sensor.

Correction of this issue requires minor modification of the Signview source code to admit second byte alarm codes for non-fog visibility as well as fog visibility. Perhaps a distinction could also be made between messages due to water fog, and those activated due to non-fog visibility alarm codes.

3.5.2.3 Pre-emption of manually placed messages by automatically-generated messages

Reference: SS 3.3.5.

The pre-emption of manually placed CMS messages by automatically-generated messages was demonstrated in the previously described events August 9, 2004 (3.3.5.1), October 10, 2004 (3.3.5.2), and December 12, 2004 (3.3.5.4). Any automatically generated message, including traffic, fog or wind warnings, replaces the manually placed message. Manually placed messages include Amber Alerts, specific traffic advisories such as lane closures ahead, and message intended to override automatic messages when they are in error. It is not always appropriate that manually placed messages be overridden by automatic messages, and Signview provides no mechanism for preventing this override.

When the automatically generated message is removed, Signview does not restore the previously entered manual message. This has lead to situations, illustrated in the cases cited above, in which an Amber Alert message intended to be displayed for several hours was removed permanently after a few minutes because of a momentary automatic message, e.g., HIGH WINDS. Signview has no provision for preventing this from happening.

Correction of these issues requires minor modifications at several locations in the source code.

3.5.2.4 Failure to log blank messages

This problem was corrected by joint effort of the evaluators and Joel Retanan August 27, 2004, prior to the 2004-05 fog season.

Prior to this, Signview only logged the times that messages were turned on, but did not log the times that they were turned off. This required the addition of one line of code in Signview module SV12A.c between lines 857 and 858:

```
AppendLog( 6 ); // log the blanking event
```

With this correction, Signview properly logged both the on and off times of each CMS message.

3.5.2.5 Possible reversal of Signview activation priorities due to polling order

The three cases of conflicts between fog and traffic activations discussed in SS 3.4.2 are suspected of being caused by the method by which Signview implements its traffic-over-fog priority. Signview was hard-coded in such a way to implement a hierarchy of speed activations outweighing weather activations,

by relying on the fact that the polling cycles of Signview for both the QCMS and TMS are equal. Yet these are set by the TMS and QCMS computers independently, and are not currently equal. The TMS computer uses a 50 second polling interval. While the QCMS computer currently uses an averaging and logging interval of 15 minutes, which is believed to define the polling interval.

This relevant section of the Signview code is in module SV8A.c starting at line 2801, in a conditional statement where both polling cycles and timers must equal in order for both computers to be polled at the same time. The order of polling, QCMS then TMS, is responsible for the activation priority. Looking at SV12A.c line 134-163, it is evident that if both computers are polled on the same cycle, then QCMS is polled first then TMS is polled allowing TMS to overwrite any flags of QCMS. In the event of unsuccessful communications with either computer, the polling timers are reset. This priority can be inadvertently and randomly upset when different polling cycles are used by the TMS and QCMS computers.

This issues required additional investigation. If correction is warranted, this will require a significant modification of this core element of the CAWS control strategy, to implement a means for enforcing activation priorities which is independent of the order in which information is available to the Signview computer from the QCMS and TMS computers.

3.5.2.6 Progressive sequencing of fog warning messages

Reference: Weather activation events of SS 3.3.3.

Each CMS is uniquely tied to a particular weather station. However, due the localized nature of fog, each station typically displays a different warning message (or none). Prior to the 2004-05 fog season, this involved different speed recommendations, which could cause confusion for drivers. This is evident in Figure 3.3.3.1.

Correction of this problem involves modification of several Signview source code modules to implement a progressive and consistent warning strategy, similar to the approach used for traffic actuations. Most important is that the visibility readings reported by successive weather stations in the CAWS be compared and a more consistent presentation of information to drivers be devised.

3.5.2.7 Need for a “reduced function mode” and a graceful degradation plan.

This is a recommendation for improvement rather than a critical fault.

Currently, all error checks related to Signview communications default to the equivalent of no warning message in the event of any type of error, including checksums or loss of synchronization. While this is a reasonable failsafe position, other options are possible due to the extensive data redundancy available to Signview.

The centralized control architecture of the CAWS system, with Signview as the primary control element, permits much more sophisticated handling of situations where field communications or field sensors may be lost. In the event of a loss of communications with a traffic monitoring site or weather station, Signview could implement a driver information strategy based on “best available information” considering the system as a whole.

3.5.3 Qualimetrics Caltrans Meteorological Monitoring System (QCMS) Software

3.5.3.1 General mode operation and interface with Signview

The QCMS uses a proprietary software package for communications with the nine field weather stations. Since we did not have access to this source code, it was not possible to analyze this program to the degree that it was possible with Signview/CAWS and TMS. However, the operational issues we have observed did not make such an analysis necessary. The detailed QCMS documentation helped to make clear how alarm levels are generated and transmitted to the Signview computer, and confirmed any possible design weaknesses we observed as intentional decisions rather than possible software bugs.

For communications with the remote weather stations, the QCMS uses its own communications network referred to as the Q-Net system, over leased phone lines. Communications protocols are not documented since they are considered proprietary by the manufacturer. The requirement that it use a completely separate leased line network for communications with field sites potentially increases the ongoing communications cost of the CAWS.

The serial communications protocol used from the QCMS computer to the Signview computer is not documented in the otherwise QCMS, which suggests that it probably was intended to be documented in the CAWS/Signview manual if it had been written. This aspect may have been co-specified or co-developed with the Caltrans developers of the Signview/CAWS program. A document “Special Provisions for Caltrans Contract Number 10-442204 was referenced in the QCMS System User’s Manual (pg. 15) but no one we contacted at either Caltrans or All-Weather systems had any knowledge of this document. Our understanding of the format of the data transfer has been determined by study of the weather log files and the interface components in the Signview source code only.

Other than the problem described below, issues related to the weather monitoring system were limited to failed or malfunctioning sensors, and problems related to the interpretation of fog alarm flags by the Signview program, addressed in the Signview software analysis.

Detailed analysis of the QCMS software was possible since the source code was not available. Fortunately, none of the issues we observed required detailed analysis beyond the level of information provided in the manufacturer’s documentation.

3.5.3.2 Persistence of QCMS alarm codes after communications failures.

The persistence of the alarm codes sent from the QCMS during a loss of field communications was observed in the previously discussed activation event cases. It is considered a critical design flaw, which could only be corrected in the QCMS software. In the event of a loss of communications with a remote weather station the QCMS program leaves the alarm codes in their present state; it does not pass any indication to Signview that the data that generated this alarm level is now invalid. Consequently, the existing message remains on the CMS indefinitely, until either communications is restored to the remote weather stations or the QCMS computer is rebooted. It is not possible to override such visibility alarm messages in Signview. Even if a message is manually placed on the CMS, less than three minutes later the message will be removed and replaced with the incorrect fog or wind related message, since the QCMS is still sending these old alarm codes, and Signview overrides all manually-placed messages with ones that are automatically generated.

The correct approach would have been for the QCMS computer to pass a special code to Signview indicating that a communications failure to that site has occurred, so that the validity of the current message is unknown. The message might be retained for a short period, but then should be automatically removed by Signview if the QCMS communications are not restored with a fixed period of time.

What if RS-232 communications is lost between the QCMS and Signview computers? This was properly anticipated in the design of Signview. If Signview does not receive data when it polls the QCMS computer, it interprets this as an unknown conditions and removes the visibility message. This is reasonable failsafe behavior, although somewhat more redundant checking of the state of the QCMS computer might avoid the possibility of removed visibility messages due to momentary communications problems between the computers.

3.5.3.3 Erroneous alarm levels during boot-up

Visibility alarms are sent from the QCMS computer to the Signview computer over a serial port connection. These are used to trigger the display of CMS messages. A packet of data is transferred for each weather station including the station number and its corresponding alarm flags. Only the alarm flags are sent, not the actual visibility readings. A problem occurs when power is restored to a weather station after an outage. On power-up, a '0' visibility reading is initially sent by the weather station to the QCMS computer. This '0' generates a Level 3 visibility alarm flag, corresponding to the most severe visibility condition. Until the visibility sensor is fully on-line, which may take as long as three minutes, activation of a CMS warning message due to this alarm is possible.

3.5.4 General Issues, All Systems

3.5.4.1 System lag due to multiple excessive polling intervals

Table 3.5.4.1 was used to determine typical and the average delay in the response of the CAWS in generating a fog warning message. The delay was the elapsed time in seconds between the moment that the fog visibility reported at WS 1 dropped below the 500 ft. alarm threshold, and the time that the corresponding message was activated on CMS 1. This table considers only the 45 mph message a activation since, the year 2004 was split between two different message display schedules, and 45 mph was common to both schedules. Data were recorded by our data acquisition systems at WS 1 and CMS 1.

Over all measurements, the average delay was 472.17 seconds = 7.87 minutes. The random and generally excessive length of the system response delay frequently caused the warning message to appear after the trigger event, such as brief but very dense fog, had passed.

Table 3.5.4.1. Response delays measured for CMS 1, 2004-05. Delay is in seconds.

SignID	Time CMS Activated	Time Fog Coef >= 31.68	Fog Coef	Start Time	End Time	Delay
69	20040130041019	20040130040556	33.21	20040130034019	20040130041019	263
69	20040130051916	20040130051855	32.20	20040130044916	20040130051916	21
69	20040204081817	20040204081807	33.95	20040204074817	20040204081817	10
69	20040308062233	20040308061646	33.91	20040308055233	20040308062233	347
69	20041107060805	20041107060627	31.68	20041107053805	20041107060805	98
69	20041111235215	20041111234944	32.83	20041111232215	20041111235215	151
69	20041112000412	20041111234944	32.83	20041111233412	20041112000412	868
69	20041112032306	20041112031610	35.15	20041112025306	20041112032306	416
69	20041112041404	20041112041107	32.06	20041112034404	20041112041404	177
69	20041112043505	20041112041107	32.06	20041112040505	20041112043505	1438
69	20041112074357	20041112073748	37.64	20041112071357	20041112074357	369
69	20041114054152	20041114052721	31.75	20041114051152	20041114054152	871
69	20041114082045	20041114081508	33.37	20041114075045	20041114082045	337
69	20041114203521	20041114203036	31.96	20041114200521	20041114203521	285
69	20041114213219	20041114213035	31.85	20041114210219	20041114213219	104
69	20041114224716	20041114224204	33.90	20041114221716	20041114224716	312
69	20041115061402	20041115061013	32.43	20041115054402	20041115061402	229
69	20041115065300	20041115064938	32.19	20041115062300	20041115065300	202
69	20041115081058	20041115080602	33.41	20041115074058	20041115081058	296
69	20041115102715	20041115102030	33.98	20041115095715	20041115102715	405
69	20041115204753	20041115204444	33.84	20041115201753	20041115204753	189

69	20041115211752	20041115211643	31.80	20041115204752	20041115211752	69
69	20041115221750	20041115220112	32.53	20041115214750	20041115221750	998
69	20041115230549	20041115230041	35.01	20041115223549	20041115230549	308
69	20041116044438	20041116042517	33.60	20041116041438	20041116044438	1161
69	20041116225952	20041116225551	36.32	20041116222952	20041116225952	241
69	20041117003846	20041117003445	33.30	20041117000846	20041117003846	241
69	20041117223154	20041117222815	32.75	20041117220154	20041117223154	219
69	20041120000806	20041120000725	32.65	20041119233806	20041120000806	41
69	20041119234708	20041119234456	33.27	20041119231708	20041119234708	132
69	20041120003207	20041120000725	32.65	20041120000207	20041120003207	1482
69	20041120045256	20041120045111	31.86	20041120042256	20041120045256	105
69	20041120091648	20041120091228	33.04	20041120084648	20041120091648	260
69	20041209213256	20041209212922	33.78	20041209210256	20041209213256	214
69	20041209221454	20041209220954	34.17	20041209214454	20041209221454	300
69	20041209223252	20041209222852	37.63	20041209220252	20041209223252	240
69	20041210220250	20041210215902	32.42	20041210213250	20041210220250	228
69	20041210221451	20041210215902	32.42	20041210214451	20041210221451	949
69	20041210232947	20041210232622	33.86	20041210225947	20041210232947	205
69	20041211001746	20041210235322	34.79	20041210234746	20041211001746	1464
69	20041213014110	20041213013703	35.93	20041213011110	20041213014110	247
69	20041213042604	20041213042121	32.62	20041213035604	20041213042604	283
69	20041213055601	20041213055515	32.01	20041213052601	20041213055601	46
69	20041213071958	20041213071543	32.48	20041213064958	20041213071958	255
69	20041213073458	20041213071543	32.48	20041213070458	20041213073458	1155
69	20041213074058	20041213071543	32.48	20041213071058	20041213074058	1515
69	20041216211013	20041216210455	34.97	20041216204013	20041216211013	318
69	20041216212213	20041216211725	33.87	20041216205213	20041216212213	288
69	20041216214313	20041216214012	33.14	20041216211313	20041216214313	181
69	20041216220113	20041216220111	31.74	20041216213113	20041216220113	2
69	20041217010713	20041217010329	33.92	20041217003713	20041217010713	224
69	20041217105013	20041217104708	35.12	20041217102013	20041217105013	185
69	20041217190215	20041217190045	33.65	20041217183215	20041217190215	90
69	20041217210213	20041217210156	32.25	20041217203213	20041217210213	17
69	20041218071413	20041218065045	34.05	20041218064413	20041218071413	1408
69	20041218215513	20041218215206	32.52	20041218212513	20041218215513	187
69	20041219043413	20041219043228	32.80	20041219040413	20041219043413	105
69	20041219045213	20041219043228	32.80	20041219042213	20041219045213	1185
69	20041219212213	20041219212112	32.18	20041219205213	20041219212213	61
69	20041219220713	20041219220303	32.22	20041219213713	20041219220713	250
69	20041219235213	20041219234927	32.04	20041219232213	20041219235213	166
69	20041220012213	20041220005626	32.51	20041220005213	20041220012213	1547
69	20041223040413	20041223035853	35.67	20041223033413	20041223040413	320

69	20041223040713	20041223035853	35.67	20041223033713	20041223040713	500
69	20041223041614	20041223035853	35.67	20041223034614	20041223041614	1041
69	20041223054613	20041223054142	32.25	20041223051613	20041223054613	271
69	20041223080113	20041223075639	34.17	20041223073113	20041223080113	274
69	20041224013414	20041224013214	33.96	20041224010414	20041224013414	120
69	20041224020113	20041224013214	33.96	20041224013113	20041224020113	1739
69	20041224034313	20041224032712	32.41	20041224031313	20041224034313	961
69	20041224045513	20041224045341	32.86	20041224042513	20041224045513	92
69	20041224051613	20041224051540	32.19	20041224044613	20041224051613	33
69	20041225021015	20041225014908	31.94	20041225014015	20041225021015	1267
69	20041225033713	20041225031436	33.39	20041225030713	20041225033713	1357
69	20041225073114	20041225072002	32.28	20041225070114	20041225073114	672
69	20041225080113	20041225075722	32.74	20041225073113	20041225080113	231
69	20041225092214	20041225091721	32.10	20041225085214	20041225092214	293
69	20041225093415	20041225093020	32.52	20041225090415	20041225093415	235
69	20041226065513	20041226065130	32.74	20041226062513	20041226065513	223
69	20050103235813	20050103235331	32.70	20050103232813	20050103235813	282
69	20050104000713	20050103235331	32.70	20050103233713	20050104000713	822
69	20050112212316	20050112212018	33.89	20050112205316	20050112212316	178
69	20050124034413	20050124031826	32.00	20050124031413	20050124034413	1547
69	20050203051513	20050203051123	33.43	20050203044513	20050203051513	230
69	20050203051813	20050203051123	33.43	20050203044813	20050203051813	410
69	20050203080913	20050203080407	43.58	20050203073913	20050203080913	306
69	20050204053013	20050204052412	35.55	20050204050013	20050204053013	361
69	20050204054813	20050204053707	35.23	20050204051813	20050204054813	666
69	20050205052713	20050205052505	32.92	20050205045713	20050205052713	128
69	20050205071213	20050205070125	33.15	20050205064213	20050205071213	648
69	20050205104513	20050205103851	32.57	20050205101513	20050205104513	382
69	20050309061723	20050309060517	34.48	20050309054723	20050309061723	726
69	20050311042114	20050311041531	35.46	20050311035114	20050311042114	343
69	20050311045714	20050311044200	32.60	20050311042714	20050311045714	914
69	20050311064514	20050311063945	33.75	20050311061514	20050311064514	329
69	20050311070016	20050311065514	38.20	20050311063016	20050311070016	302
69	20050312040915	20050312040612	37.21	20050312033915	20050312040915	183
69	20050312043614	20050312041707	32.43	20050312040614	20050312043614	1147
69	20050312044214	20050312041707	32.43	20050312041214	20050312044214	1507
69	20050312050614	20050312050237	34.55	20050312043614	20050312050614	217

The worst-case delay attributable to polling periods can be calculated as follows, based upon information provided to us by system operators or evident in the program source code:

Traffic activations:

TMS field polling interval: 50 seconds, and three polling cycles are required to fully recognize an speed condition at a site: 150 seconds or 2.5 minutes maximum recognitions time.

TMS computer is polled by Signview once every three minutes.

Total maximum delay possible for Signview recognition of traffic triggers: 5.5 minutes

Fog activations:

The QCMS averaging and logging cycle limits the information update rate, even if field sites are polled more often by the QCMS computer. The current averaging and logging interval is set to 15 minutes. The actual field-polling interval used by the QCMS system is not documented, but it is reasonable to assume that it is the same as the averaging and logging interval, and this is the understanding of the system operators. We understand that the logging interval was originally set by Qualimetrics to 5 minutes, but was changed to 15 minutes by district personnel some time prior to the first year of our driver behavior observations as a way to reduce the massive accumulation of log file entries, which required periodic manual backup.

QCMS computer is polled by Signview polling once every three minutes.

Total maximum delay possible for Signview recognition of fog triggers: 18 minutes

The 7.9-minute average delay for fog message activations that we have observed would be consistent with this figure, since it is approximately half of the maximum possible delay.

Signview is capable of asynchronous placement of manual messages, but it appears that Signview updates the CMSs at the end of its fixed three-minute polling period after it polls the QCMS and TMS computers. This period is therefore not added to the maximum polling-related system response delays calculated above.

In the event of any communications failure between the field sites and the QCMS or TMS computers (reasonably likely), or between these computers and the Signview computer (not likely), these periods can be extended significantly by integer multiples of the maximum polling delay.

The operational ramifications of the activation delays are reduced relevance of warning messages, especially those for fog. We examined the relative amounts of time the CMS 1 correctly and incorrectly displayed fog warning messages, by comparing the output of the fog sensor at weather station 1 with the

CMS signal at CMS 1. Table 3.5.4.2 shows results for the 17-month active study period including both the 2003-04 and 2004-05 fog seasons, during which a total of 166 fog activation events occurred.

Table 3.5.4.2. CAWS activation delay for fog messages at CMS 1.

	Visibility				CMS Message		
	<500ft	>500ft	Total	Events	With Fog		Without Fog
					None	Fog	Fog
Total duration in minutes	11145	732928.5	744073.5	166	2557	8588	2042.5

The table shows that during this period a fog warning message was displayed which matched the actual warning threshold conditions a total of 8588 minutes. But for 2557 minutes, no message was displayed when one was warranted. And for 2042 minutes, a fog warning message was displayed even though conditions no longer warranted it. (Times that a traffic warning message superceded the fog message were counted as valid fog messages.) The numeric symmetry between the failures to warn and the false warnings strongly suggests that the majority of all improper warning states were due to activation lag rather than other control issues.

3.5.4.2 Need for sensor validation and graceful degradation

With significant redundancy of both weather and traffic data, a more sophisticated control scheme is possible by which data from proximate sensors is compared to assure validity. For example, an unrealistic but non-zero speed report from one lane at a traffic site could be rejected as unreliable when compared with the adjacent lanes. Current provisions are restricted to ignoring lanes with zero counts or reported mean speeds over 150 mph. It should also be possible to activate a fog warning message on a CMS even if communications is lost to the weather station which usually actuates it. There are currently no such provisions in Signview or alternatively, the TMS or QCMS computers.

3.5.4.3 Lack of documentation and operators manual

No formal documentation was provided for the operation, maintenance or troubleshooting of the CAWS/Signview or TMS programs. While the original (incorrect) mapping of traffic monitoring sites to CMSs was documented, and District personnel believed this to be current, the actual mapping that was corrected in 1997 was not documented. In-line comments in the Signview and TMS source code were also minimal, making it difficult for programmers to later diagnose possible bugs or implement code fixes or upgrades.

3.5.4.4 Time synchronization between the three CAWS computers

The system clocks on the three CAWS system PCs are independent. Typical differences of 5-10 minutes are observed by TMC personnel during monthly maintenance. As non-networked DOS and Windows

computers, the clocks must be manually corrected for drift. Since local system times determine the event times in each log file, any time differences between them can lead to possibly erroneous conclusions regarding the synchronization of speed and visibility detection and the resultant display action.

3.5.4.5 CMS messages remain in event of system failure

There is currently no way to extinguish a CMS message in the event of a loss of communications with a CMS site. In extreme cases, District personnel must physically go out to the CMS site, open the cabinet and disable the message by manual entry to the 170 controller.

There are two possible, possible concurrent solutions:

1. A message time-out could be implemented in the TMS client software running on the 170 controllers for message activation. In the event of a loss of communications with the Signview computer, the message could be deactivated automatically at the field site until communications is restored.
2. An emergency redundant communications path could be provided, such as a dial-back cellular phone modem, or a CDMA or GPRS modem.

3.5.4.6 Binary (non-text) log files

The Signview and TMS computers generate log files which are not text readable. They were designed to only be read via the programs themselves, on a single day basis. This made it very difficult for District and other Caltrans personnel to perform the needed testing of the system, which requires the observation of data over extended periods of time. This also made the evaluation of the system very difficult. After the evaluators were given access to the source code for the Signview and TMS programs, we reverse engineered separate utilities to convert the binary log files into text-readable files. These utilities are included in the CD distributed with this report, and their use is fully described in Appendix 3.8.2. The log files generated by the QCMS program were text-readable and required no conversion.

3.6 Specific Recommendations for Corrections to Software or Control Strategy

We summarize our observations here as an action list, each problem followed by a specific recommendation for corrective action. Resolution of some of the problems will require the reconsideration of some elements of the control strategy. No hardware changes are required. *All recommendations involve only changes to system software.* These recommendations were originally presented to Caltrans district and HQ personnel on April 21, 2004.

We note that the recommended software modifications and upgraded software versions should conform to industry standards of software engineering and quality assurance, including adequate design review, alpha and beta testing, debugging and corrective redesign, field testing, continuous software support, and complete documentation of both the code and operational attributes of the software, especially with regard to the control strategy. These requirements are of particular concern due the application in public safety.

3.6.1 Critical Recommendations

1. CMS warning messages that are activated by visibility thresholds are tied uniquely and individually to the most proximate weather station. One station activates only one CMS, providing no additional advisory message in advance of the warning message. No sensor validation is done, which would indicate if a sensor is malfunctioning or inconsistent with surrounding sensors. Since fog is often a localized phenomenon, and the local CMS responds only to a local condition, the conditions are created for the variable sequences of different warning messages we have observed. We note that this activation strategy differs from the speed-activation strategy, in which the advisory message "HIGHWAY ADVISORY AHEAD, CAUTION" is displayed on the CMS just prior to the warning CMS, and multiple CMSs can be activated based upon a speed threshold trigger from a single site, including the ability to activate both CMS 5 and 9 in advance of the Y.

Recommendation: The visibility-related control strategy should be changed to include inputs from multiple sensors in the sign activation decisions, and provide outputs to multiple coordinated CMSs to implement progressive and consistent warnings, including coordinated warnings at the entrance to the Y. This will require significant modification of the Signview code to implement a redesigned activation strategy for visibility-related warning messages.

2. On January 2, 2003 (just prior to the first year of our two-year observation period), the two visibility-related warning messages were changed from the original general warnings "FOGGY CONDITION AHEAD" and "DENSE FOG AHEAD, CAUTION" to specific speed recommendations "DENSE FOG, ADVISE 45 MPH" and "DENSE FOG, ADVISE 30 MPH". These messages were expected to be more effective in altering driver behavior, and encouraging a specific speed compliance target. However, in

light of the local activation problem described in (1), this specificity could encourage greater speed variance, as different speed advisories are presented to drivers on each successive CMS.

These messages were changed again in April 2004, with both the 30 and 45 MPH messages replaced with a single 45 MPH advisory message that is displayed for all fog visibilities below 500 feet. This is also potentially problematic since such an advisory might be misconstrued as a recommended safe speed during very low visibility conditions, for which lower speeds would be appropriate. A safe speed at 100 feet visibility is, from PCS calculations, about 31 mph, consistent with the prior higher-level warning.

Recommendation: If the control strategy is not modified as suggested in (1), the speed-advisory visibility-related automatic warning messages should be changed back to the original non-speed-specific warning messages. Until the above-cited activation problems are corrected, and appropriate messages are displayed for each level of visibility and traffic, no specific speed advisory should be displayed. This involves changing two lines in the Signview automatic sign activation message table. This does not require recompiling the code.

3. Signview does not respond to QCMS alarm level 3, the most severe visibility condition. Prior to summer 2004, this meant that when visibility drops below 100 feet, the previously displayed visibility-warning message is extinguished and no message is displayed. (In summer 2004, a temporary work-around was implemented by District personnel, as discussed below).

Recommendation: The Signview program should be modified to include detection of the third (lowest visibility) alarm flag, and tied to the display of an appropriate warning message, subject to the coordination requirements discussed in (1) above. This will require a small change to the Signview code.

4. CAWS currently does not detect smoke or dust, no matter how much of a visibility impairment this is. Fog is distinguished from other visibility conditions by a relative humidity (RH) reading greater than 75%. This is accomplished by use of an integrated temperature/relative humidity (RH) sensor. If the RH is low, fog is not reported regardless of the visibility.

If the temperature/RH sensor fails or is out of calibration, the QCMS reports a low visibility alarm, but not a fog alarm. Signview currently responds only to fog threshold alarms, not low visibility alarms. This is somewhat understandable, since the corresponding CMS warning messages contain the word "fog". However, if the temperature/RH sensor fails or is out of calibration, fog alarms are not generated even if the visibility sensor is reporting very low visibility.

Recommendation: The Signview program should be modified to react to both "fog" and "low visibility" threshold alarms, subject to the coordination requirements discussed in (1) above. This will require several small changes to the Signview code.

5. CMS activation is not triggered by a monitoring site if the loop detector pair in any lane is reporting a speed of greater than 50 mph regardless of how slow the speeds are in the other lanes. Many of the loop

detectors are prone to occasionally report erroneous data, most often excessively high speeds as a result of false triggering. As documented previously, we have observed a number of situations in which warning messages were not activated or were delayed, possibly as a result of this algorithm. This also leads to problems with detection of traffic backups in the five-lane merging section following the I-5 / SR120 Y as discussed in prior subsections of this document.

Recommendation : Redesign the speed trigger generation algorithms and implement corresponding changes to the TMS program code. The ramifications of all control actions must be examined at an appropriate level of detail, including consideration of sensor failure scenarios. No specific action is suggested until we have more complete information, including either documentation on the internal operation of the SV170 code or the actual SV170 code.

6. The system response lag time has been observed to vary from 3 to 5.5 minutes for traffic activations, and 3 to 18 minutes for fog activation events, with an average delay of 7.9 minutes. This lag pertains to deactivation of the CMS as well as activation. Fog sensor direct readings indicate that visibility readings change radically in the CAWS area in as little as three minutes. These delays appear to be attributable to the fixed sensor polling periods combined with the CMS update polling periods. Excessive lag times, especially with a high degree of variability, may diminish the relevance of a warning message, and undermine driver confidence in the validity of the warnings/advisories.

Recommendation 1: In the immediate, the polling intervals for both speed and visibility data acquisition and CMS activation should be reduced. This may require code modifications, or may require only a number change in a configuration file. Since the current software writes a usually benign entry in the system log file with every polling cycle, it would also be advisable to modify the logging schedule to make it independent of the system polling interval, to prevent it from logging benign events which eventually result in huge log files.

Recommendation 2: In the longer term, because of the real-time nature of the warning system, this system should respond immediately to trigger events, rather than relying on traditional fixed polling intervals. This involves asynchronous communications with field elements via messaging rather than periodic polling. Correction of this design limitation may require significant re-coding of Signview and/or TMS, as well as the communications code running on the SV170 field controllers.

7. Messages manually entered at the Signview console are overridden by automatic messages generated by Signview. Manual messages are usually traffic advisories or Amber Alert messages. However, when the automatic actions of the system are incorrect, as we have observed in the situations described previously, this priority prevents operator override of the incorrect action. Also, the manual message is not restored once it is overridden by the automatic message, even when the automatic message is removed.

Recommendation: Signview code should be modified to allow manual override of automatically-generated CMS messages when intended by the system operator, and automatic restoration of the manually-placed message when the automatic warning has ended. This will require limited changes to the Signview code.

8. When communications from the weather stations is down, the information periodically transmitted to the Signview computer from the QCMS computer remains the same as the last entry logged by the QCMS. This leaves the fog warning message activated, even long after the end of the fog event. It is also a problem if communications is lost just prior to a fog event.

Recommendation 1: Signview code should be modified to recognize when the QCMS (weather system) is down, and not continue to act upon stale visibility flag information. This can be discerned from other data available from the QCMS. The complexity of the required code modifications is uncertain.

Alternatively, the program that transmits data from the QCMS computer to the Signview computer may be modified by the system vendor (All-Weather Systems) to reset the alarm flags when data is invalid from the visibility sensor. There is evidence that communications from the QCMS is handled by a separate program, that runs externally from the QCMS program, which periodically reads the most recent entry in the QCMS log file. The authorship of this program is unknown.

Recommendation 2: A superior but more complex alternative to the basic corrections above would be to modify Signview to utilize visibility alarm information from other proximate weather stations as a substitute for defective data when a given weather station is down. Such a change would best be implemented in conjunction with the correction of Problem 1, above. This latter change would require redesign of the visibility-related activation strategy and more extensive modifications of the Signview Code.

9. Visibility alarms sent from the QCMS computer to the Signview computer can falsely generate severe fog warning message activations, as previously discussed.

Recommendation 1: The ideal solution would require that All-Weather Systems, the vendor of the QCMS, modify their code to withhold alarm trigger generation during the boot-up or recovery of a field system following a power outage. It should recognize that a zero visibility reading is impossible and represents an error condition rather than an actual visibility for which an alarm should be triggered.

Recommendation 2: The Signview code could be modified to prevent the incorrect actuation of visibility warning messages during boot-up of a weather station. A boot-up condition could be detected from the status data sent from the QCMS computer.

Recommendation 3: (Long term solution.) Transmit actual visibility readings from the QCMS to Signview rather than just alarm flags triggered by the QCMS program. This would allow Signview to make more intelligent decisions about visibility-related CMS actuations, including the detection of "0" visibility as an error condition. This would constitute a significant change to the Signview program, and if attempted, would best be implemented in conjunction with solutions to Problems 1, 4, 9 and 11.

10. TMS communications error checking algorithms could potentially cause the TMS computer to hang up in the event of corrupted communications or signal noise.

Recommendation: The communications module of the TMS program code should be reviewed and modified to prevent modes in which the 'while loop' could fail to terminate, or the data buffer could overrun.

11. As documented previously, under some circumstances, the prioritization of traffic warnings over fog or wind warnings can be temporarily reversed as a result of unequal polling cycles.

Recommendation: Signview code module SV8A.c must be modified to implement a different method of enforcement of warning message priorities that does not rely on the polling update sequence. This may require a significant modification of this core element of the CAWS control strategy.

3.6.2 Non-critical but strongly recommended corrections

12. Speed-related CMS messages appear to ultimately be triggered by individual detector events. One detector can activate multiple signs, and it always provides a "Highway Advisory Ahead" on the CMS immediately prior to the warning message. This is a valuable feature. However, the converse does not appear to be true. While prioritization of individual detector triggers is implemented, no provision exists for generation of optimal message deployments based upon system-wide combinations of detectors, e.g., if triggers from both detector A and detector B then a control action different than either one alone. No provision is apparent for sensor validation or cross-checking other than out-of-range tests; thus an out of calibration detector showing persistently low speeds could potentially trigger false "SLOW TRAFFIC AHEAD" or "STOPPED TRAFFIC AHEAD" messages. Similarly, an excessively high (over 50 mph) speed reading in a single lane or failed communications can inhibit activation of messages, as discussed previously.

Recommendation 1: The activation strategy should be redesigned to provide provisions for sensor validation and multi-sensor consensus-based activation decisions. This involves a possibly significant change to the code. We have not yet been able to determine if this situation has led to actual operational problems. Careful study of control ramifications is advised before design and code changes are implemented.

Recommendation 2: We note that the only available documentation of the sign activation strategy is misleading to system operators since it is titled "SPEED/FOG WARNING MESSAGE TABLE". It actually only pertains to speed-related warning messages. It is also inconsistent with the actual activation table STNIDCMS.MAP found to be in current use by Signview.

Recommendation 3: (Long term solution.) Transmit actual speed data from the TMS computer to Signview rather than just flags triggered by the QCMS program. This would allow Signview to make more intelligent decisions about visibility-related CMS actuations, including the consideration of both visibility

and speed data in the generation of optimal warning message deployments. This would constitute a significant change to both the TMS and Signview programs, and if attempted, would best be implemented in conjunction with Problem 5.

13. The lack of logging of automatic CMS blanking messages by Signview prevents accurate determination of when a message is “turned off”. This makes post-analysis of system actions difficult.

Recommendation: This requires only a small change in the Signview code and should be fixed as soon as possible in order to provide valid and complete CMS activation records. This correction has no impact on public safety, but is critical to the successful evaluation of the system.

14. The system clocks on the three CAWS system PCs are independent. Typical differences of 5-10 minutes are observed by TMC personnel during monthly maintenance. As non-networked DOS and Windows computers, the clocks must be manually corrected for drift. Since local system times seem to determine the event times in each log file, any time differences between them can lead to possibly erroneous conclusions regarding the synchronization of speed and visibility detection and the resultant CMS display action.

Recommendation: We advise the use of some inter-system time synchronization mechanism to improve the time relationship between the three systems’ log files. In the present non-networked implementation of CAWS, this would involve one computer providing a time/date reference for the other two computers. While this is critical to the proper logging of system activities and therefore critical to the evaluation, it is not a traffic safety issue since it does not affect the real-time operation of the system.

15. The nominal TMS event logging interval is 15 minutes, even though the polling interval is 50 seconds. CMS activation decisions are based upon an aggregation of the three most recent 50-second speed polling intervals, a total period which is shorter than the 15-minute nominal TMS logging interval.

Recommendation: TMS event logging should be synchronized with its triggering actions (which cause Signview to activate warning messages) to permit accurate post-study of speed-related sign activation decisions.

16. The CAWS system, especially the TMS and CAWS/Signview programs, do not have any formal documentation or operator’s manuals. In-line comments in the Signview and TMS source code were also minimal.

Recommendation: A detailed comprehensive user’s manual should be provided for District operators. Adequate and detailed design documentation should be provided for use in troubleshooting, maintaining and upgrading these programs and the related system hardware.

17. CMS messages remain in event of system failure or loss of communications.

Recommendation 1: A message time-out could be implemented in the TMS client software running on the 170 controllers for message activation. In the event of a loss of communications with the Signview computer, the message could be deactivated automatically at the field site until communications is restored.

Recommendation 2: An emergency redundant communications path could be provided, such as a dial-back cellular phone modem, or a CDMA or GPRS modem.

18. The Signview and TMS computers generate binary log files that can only be read from within each program.

Recommendation: Modify the TMS and Signview programs to write plain text log files rather than proprietary binary formats.

3.6.3 Other Advised Improvements

Sensor validation and graceful degradation

With significant redundancy of both weather and traffic data, a more sophisticated control scheme is possible by which data from proximate sensors is compared to assure validity. For example, an unrealistic but non-zero speed report from one lane at a traffic site could be rejected as unreliable when compared with the adjacent lanes. Current provisions are restricted to ignoring lanes with zero counts or reported mean speeds over 150 mph. It should also be possible to activate a fog warning message on a CMS even if communications is lost to the weather station which usually actuates it. There are currently no such provisions in Signview or alternatively, the TMS or QCMS computers.

Currently, all error checks related to Signview communications default to the equivalent of no warning message in the event of any type of error, including checksums or loss of synchronization. While this is a reasonable failsafe position, other options are possible due to the extensive data redundancy available to Signview.

The centralized control architecture of the CAWS system, with Signview as the primary control element, permits much more sophisticated handling of situations where field communications or field sensors may be lost. In the event of a loss of communications with a traffic-monitoring site or weather station, Signview could implement a driver information strategy based on “best available information” considering the system as a whole.

Provisions for control hardware redundancy

Considering the potential safety ramifications or a partial or complete failure of the CAWS system, and its impact on driver confidence in the system, it may be advisable to provide redundancy for the

computational and communications elements. For example, the evaluation field data acquisition systems use dual redundant communications mechanisms at all sites where this is possible: CDPD modem wireless and copper leased phone lines. Data are automatically stored on two systems and two forms of media at any time, and the evaluation server implements redundant disk storage via disk drive mirroring.

These features could be implemented also for the CAWS control computers. All low cost and can help to assure against system downtime. In addition, the availability of hot spare computer, already configured to immediately replace any of the CAWS computers is strongly advised. Currently, the failure of any of the three computers can potentially lead to days of system down time as a replacement computer is acquired or constructed, and configured to replace the failed unit.

Active notification of system operators in case of problems

Another feature used by the evaluators to assure against data loss is automatic cell phone paging by the system in the event of a critical system problem such as the loss of communications with a field site or a problem with the CAWS Evaluation Server. The same approach could be used by the Signview computer to alert operators of the problems with either field elements or any of the three CAWS central computers. This would assure a rapid response to keep the system operational and operating correctly, which could possibly help to improve driver confidence in the system.

Auto-archive feature

Current practice requires that on a monthly minimum basis, log files from each of the computers must be backed up to tape or CD. Each computer has its own procedure and media. The use of a separate network-connected backup server, which implements common automated system backups would reduce this burden on District staff, and assure consistent and continuous data logs for all systems. The CAWS Evaluation System uses such an approach, which reduces the need for periodic attention by operators, and assures against any possibility of data loss.

Public dissemination of CAWS weather or traffic system

The CAWS system is isolated from the public. Yet it has the potential to provide trip planning information to drivers via the Internet or other real-time dissemination mechanisms such as or Highway Advisory Radio. The CAWS weather server constructed by the evaluators and located in the District 10 TMC already provides a color-coded map of weather conditions throughout the CAWS area. It monitors the serial data generated by the QCMS computer en route to the Signview computer. It can easily be enhanced to provide traffic information as well, if direct connection to the TMS or Signview computers was facilitated. But this server is accessible only on the Caltrans District 10 local area network, and is isolated from the Internet because of current Caltrans security policies. If Internet access was allowed, it would be a nearly trivial matter to use this existing resource as safety-enhancement tool for drivers in advance of travel through fog. Since the best way to improve traffic safety in fog is to discourage drivers

from driving in fog, this resource could potentially provide a significant safety benefit. Improved open information on the CAWS system may also help to improve driver awareness and confidence in the system.

3.6.4 Corrective Actions Completed to Date

Item 3 (Signview does not display a message corresponding to visibility alarm level 3 (100 feet or less). This problem was circumvented by District staff when they replaced the 45/30/blank message sequence with a single message “DENSE FOG AHEAD, ADVISE 45 MPH” for all visibilities below 500 feet. The problem was fixed by resetting the visibility alarm threshold via the QCMS program’s configuration user interface to 0 feet. This meant that the level 2 alarm (which was left at 200 feet) would remain in effect for all visibilities below 200 feet, including those below 100 feet. The also replaced the level two ADVISE 30 MPH” message with the same “ADVISE 45 MPH” message as level 1 alarms. This was a very resourceful way of correcting a problem that could not otherwise be corrected without modification and re-compiling of the Signview C source code. As noted above, however, advising 45 mph when visibilities are below 100 feet may or may not be the best approach. Indeed, drivers continue to drive above 60 mph even when advised to drive 30, but the safe speed for visibility below 100 feet is 31 mph based on PCS calculations.

As discussed earlier in this document, **item 13** (failure to log blanking messages to the Signview logs) was corrected by a cooperative effort of the evaluators and Joel Retanan of Caltrans HQ. We identified where a single line should be added to one of the Signview code modules to cause the program to write to its log files the time that a message is turned off. The code change was made by Mr. Retanan and the module recompiled.

Item 14 (lack of time synch between computers) was rectified by the installation of precision real-time cards in the Signview and TMS computers. This is considered a temporary fix, since it does not actually synchronize the clocks of the three computers. But the precision time bases in each computer are guaranteed to drift no more than 0.5 second per month. So if properly initially set, the computers would remain adequately time synchronized for the duration of at least the 2004-05 evaluation year. We still advise that the computers be synchronized over a local area network using a common NTP time server. We implemented an NTP time server in the District 10 TMC for this purpose as part of the CAWS Weather Server we constructed at the request of the District. However, since the CAWS computers are not connected to any network, they cannot communicate with the time server, event though it is physically adjacent to the three CAWS computers.

Item 16 (lack of documentation). To a partial degree, the operation of the CAWS system and the TMS and Signview programs are discussed in the “Technical Deliverables” volume of this final report.

Item 18 (binary log TMS and Signview log files). The evaluators created utility programs to convert these files into plain text readable form. These utilities are included in Appendix 3.8.2.2 and 3.8.2.4.

3.7 Technical and Operational Assessment General Conclusions

The CAWS was an ambitious project, and the system is remarkable in both the scope of its capabilities and potential. It provides a wider range of features and incorporates a greater level of autonomous decision-making ability than any other system in the world. It incorporates better and more extensive weather information equipment than any other deployment in the USA. It has the ability to progressively warn drivers of impending traffic hazards, and do so automatically, so that it functions consistently on a 24-hour basis. It has been in operation continuously for nine years.

From a hardware point of view, the system was very well designed and implemented. In fact, the complement of weather instruments at each of the none remote weather stations was clearly overkill, since fewer than half the instruments are actually used by the CAWS control strategy. The use of loop detectors for speed measurement was and continues to be problematic, but there are probably no reasonable alternatives. The use of leased-line communications remains the most frequent cause of partial failure of the system, affecting both the traffic and fog warning capabilities of the CAWS.

We found a number of significant problems with the control strategy of the CAWS as implemented by software running on all three computers that control the CAWS. Some of these problems make the system less effective; some make it difficult to operate and maintain. Some cited issues, in particular the response lag of the system, may contribute to a possible reduction in driver confidence in the system. Most of the control-related issues are rooted in either non-optimal control design decisions, software design errors, or software coding errors. We have investigated each and reported our findings herein. Most of these issues can be corrected in an upgrade of the existing system software; the basic programs are sound, and need not be replaced. Eleven of the eighteen recommendations are considered critical.

Finally, over the course of this study, a number of institutional issues were also revealed that may be of interest in decisions to deploy future systems of this type:

- The need to support the deployment and operation at a much higher level of resources, and with the continued active involvement of HQ research and operations staff. The size and complexity of the system were noteworthy among Caltrans ITS projects: The system includes 210 inductive loop detectors, and 72 precision weather instruments, communicating over 45 individual telecom circuits. A system of this sophistication is fundamentally different than other road improvement project. It is an on-going commitment that requires diligent periodic and fast-response maintenance, calibration, and attention to a large number of points of potential failure.
- The need for a much more formal and better-resourced software development effort, including extensive pre- and post-release software testing and off-line laboratory simulation prior to deployment.

- The need for adequate documentation is critical. Lack thereof is more than just an issue in system maintenance. We found fundamental system control characteristics that the system operators had misconceptions about (e.g., the ability to detect smoke or dust, the critical roles of the RH and day/night sensors in fog detection, how speed alarms were generated, and lack of a message when visibility fell below 100 feet, restoration of manually placed messages after being pre-empted by automatically-generated messages).
- Better management and dissemination of public information about the CAWS to improve driver awareness and confidence in the system.
- Greater study is needed on the warning message text to be used for greatest safety effect, in view of the actual operational characteristics of the system, and the reaction of drivers as discussed in the Driver Response Analysis volume of this report.
- The need for evaluation mechanisms to be built into the original system design. A major part of the first two years of the evaluation project were spent on the construction of evaluation test sites on the highway, and negotiation of access to CAWS information sources. This might have been precluded if specific provisions for evaluation had been built into the CAWS project, and the evaluation team had input into the design process. The destruction of the loop detectors at the BCMS evaluation test site by road construction also introduced an unnecessary delay. Better coordination of construction activities with evaluation activities would also be beneficial.

Recommendations contributed just prior to final report release by Expert Advisory Panel:

The functioning of the CAWS, apart from some misoperation as carefully explained in the report, I have some doubts on the functional choices that have been made. First, indeed as explained, it is very pity that for the first year the message to the driver in real reduced visibility of less than 100 feet (about 30 m?) has been a blank sign instead of even a more reduced speed advice than for the range between 100 and 200 feet (30-60 m!!). I do not agree with displaying 45 mph for the whole range of sight distances in the second year. In my opinion the strength of a fog warning systems is not only warning for fog, but also to give an explicit speed advice (or better speed limit) to have more uniform behavior given the prevailing conditions. In that sense, a speed advice of 45 mph for a visibility range less than 30 m is unrealistic and much higher than drivers accept themselves without support system. That is exactly the same as happened in the Netherlands for the rare cases of very limited sight distance, that drivers with the system (indicating a speed of 60 km/h) were actually drove faster than without system. In fact, the speed advice had influence on driver behavior, drivers relied on the system, but when the system is giving the wrong message the final outcome is worse. On the other hand, when the visibility range is between 500 and 200 feet (about 150 – 60 m), the speed advice of 45 mph is only reasonable at the lower end of the range, and most often drivers would drive faster since they think they are capable of dealing with the situation given the visibility condition. If some drivers would fully rely and comply to the system but others

just stick to their own observation one could even increase speed difference among successive drivers. So, I would propose a system that gives speed advices (or even better maximum speed limits) that are directly related to the visibility range, not too high, but not too low either in order not to reduce the credibility of the system.

3.8 Appendix

3.8.1 TMS Control Mapping

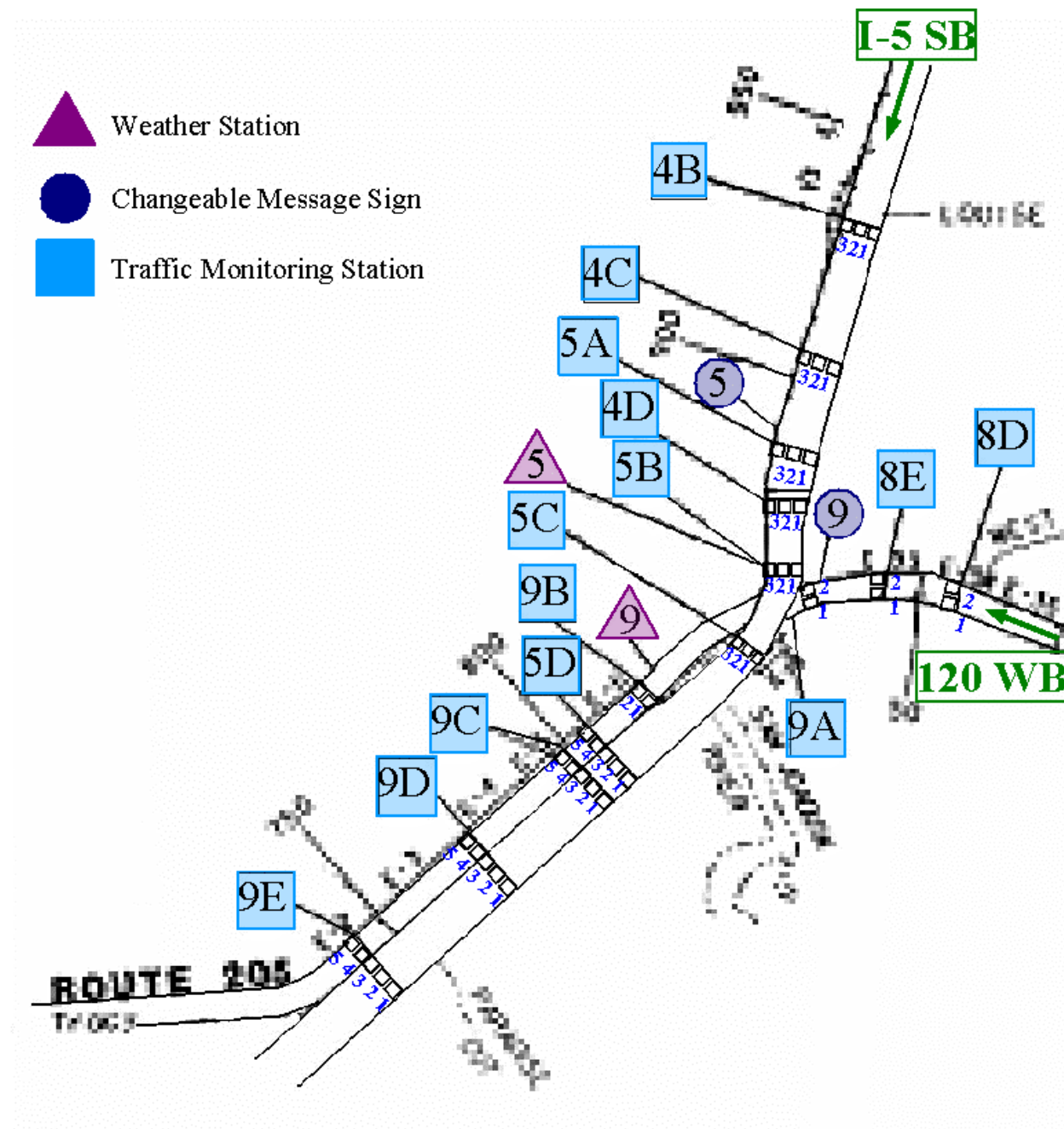

Figure 3.8.1.1. 'Mosssdale Y' Speed Monitoring Station Locations.

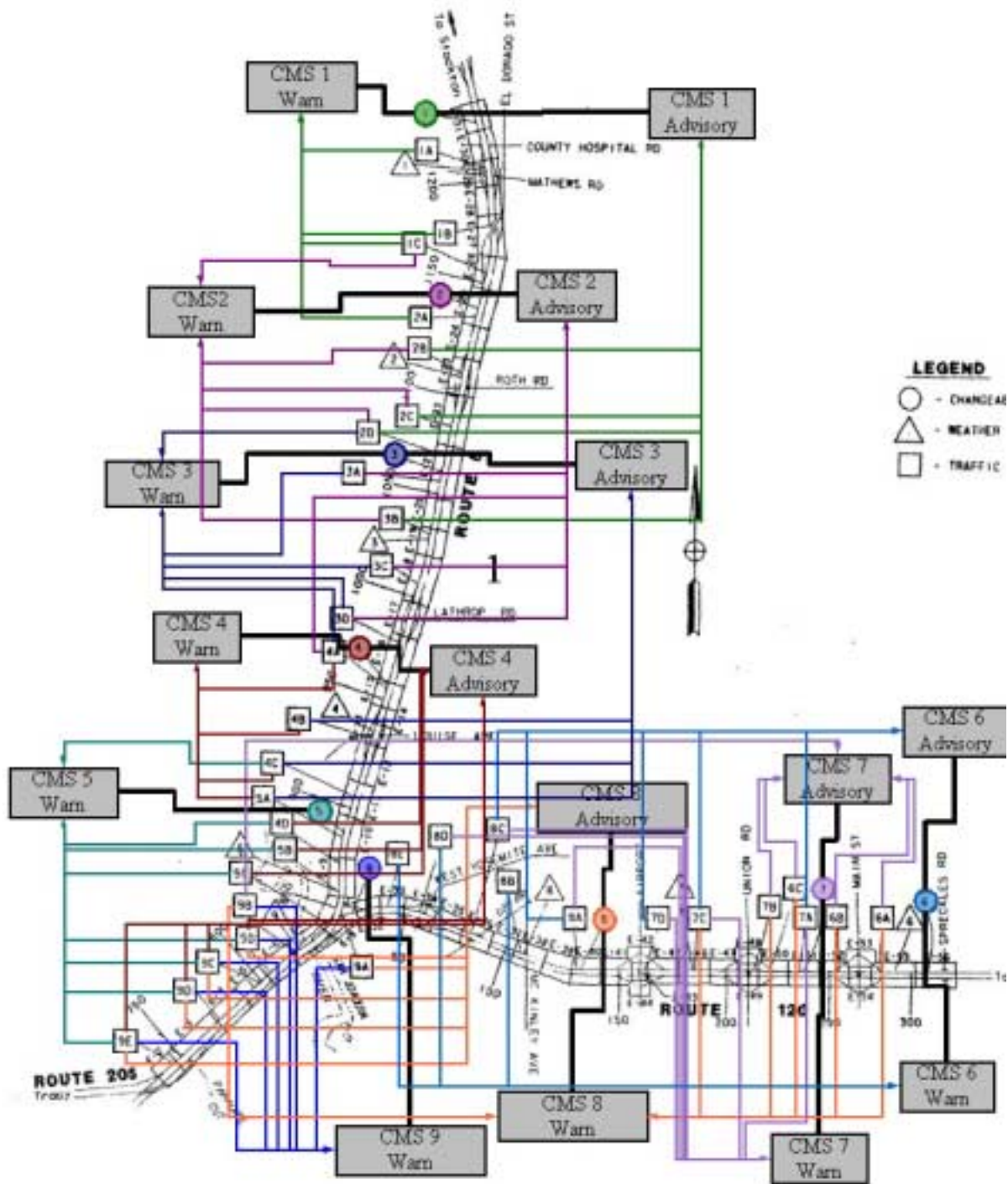

Figure 3.8.1.2. TMS Original Control Mapping, CMS <-> Speed Monitoring Stations.

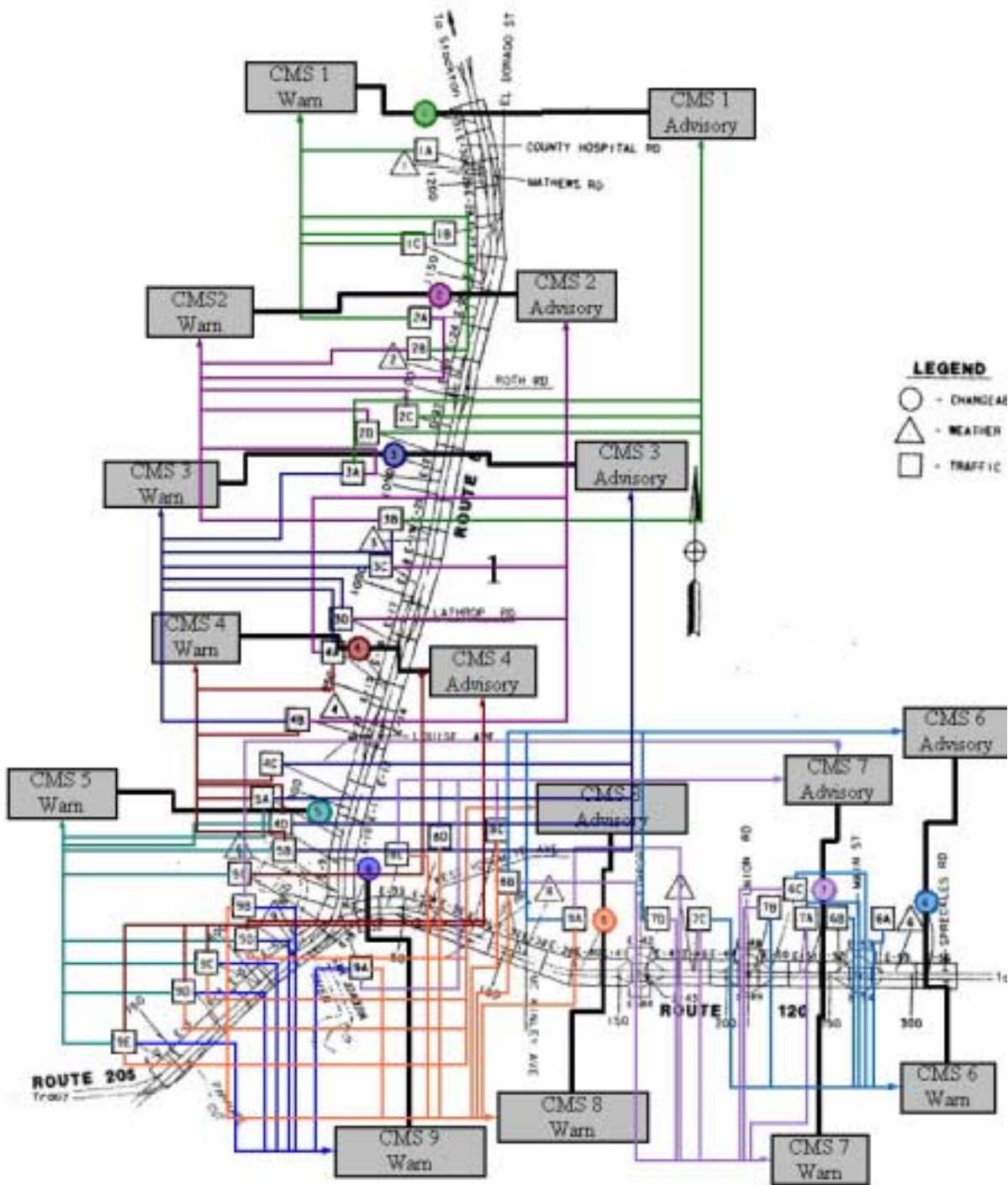

Figure 3.8.1.3. TMS Current Control Mapping, CMS <-> Speed Monitoring Stations.

Table 3.8.1.1. TMS Original Control Mapping Table.

Station ID	CMS 1	CMS 2	CMS 3	CMS 4	CMS 5	CMS 6	CMS 7	CMS 8	CMS 9
1A	WRN								
1B	WRN								
1C	WRN	WRN							
2A	WRN								
2B	ADV	WRN							
2C	ADV	WRN							
2D	ADV	WRN	WRN						
3A		ADV	WRN						
3B	ADV	WRN							
3C		ADV	WRN						
3D		ADV	WRN						
4A		ADV	WRN	WRN					
4B			ADV	WRN					
4C			ADV	WRN	WRN				
4D				ADV	WRN				
5A			ADV	WRN					
5B				ADV	WRN				
5C				ADV	WRN				
5D				ADV	WRN			ADV	WRN
6A							ADV	WRN	
6B							ADV	WRN	
6C							ADV	WRN	
7A						ADV	WRN		
7B							ADV	WRN	
7C						ADV	WRN	WRN	
7D						ADV	WRN		
8A						ADV	WRN		
8B						WRN			
8C						ADV	WRN		
8D						WRN	WRN		
8E						WRN			
9A									WRN
9B							ADV	WRN	WRN
9C				ADV	WRN			ADV	WRN
9D				ADV	WRN			ADV	WRN
9E				ADV	WRN			ADV	WRN

Table 3.8.1.2. TMS Current Control Mapping Table.

Station ID	CMS 1	CMS 2	CMS 3	CMS 4	CMS 5	CMS 6	CMS 7	CMS 8	CMS 9
1A	WRN								
1B	WRN								
1C	WRN								
2A	WRN	WRN							
2B	WRN	WRN							
2C	ADV	WRN							
2D	ADV	WRN							
3A	ADV	WRN	WRN						
3B	ADV	WRN	WRN						
3C		ADV	WRN						
3D		ADV	WRN						
4A		ADV	WRN	WRN					
4B		ADV	WRN	WRN					
4C			ADV	WRN					
4D			ADV	WRN	WRN				
5A			ADV	WRN	WRN				
5B			ADV	WRN	WRN				
5C				ADV	WRN				
5D				ADV	WRN				WRN
6A						WRN			
6B						WRN			
6C						WRN	WRN		
7A						WRN	WRN		
7B						WRN	WRN		
7C						WRN	WRN		
7D						ADV	WRN		
8A						ADV	WRN	WRN	
8B						ADV	WRN	WRN	
8C							ADV	WRN	
8D							ADV	WRN	
8E							ADV	WRN	
9A							ADV	WRN	WRN
9B							ADV	WRN	WRN
9C				ADV	WRN			ADV	WRN
9D				ADV	WRN			ADV	WRN
9E				ADV	WRN			ADV	WRN

3.8.2 Data Conversion Utilities

A series of programs were developed by the evaluators to aid in the reduction and interpretation of data in the TMS, Signview and QCMS log files. Source code as well as Windows executables and documentation for each utility are included on the CDs delivered with this volume of the report, along with the translated CAWS system data log files. These may also be download from ftp://caws-evaluation.loragen.com/var/conv_util/.

Below is a complete description of each utility and instructions for its use.

3.8.2.1 D-10 Analyzer

The D-10 Analyzer is a Borland C++ application developed to graphically view data from field computers in order to locate possible problems with site being evaluated. [Source Code/D10-Analyzer/].

Limitations: This application only works with current database structure and the site being evaluated. This software has only been tested on Win 2k machines.

Setup: In order to use this program, an ODBC connection must me made to the database:

1. Open Control Panel -> Administrative Tools -> Data Sources (ODBC).
2. Click 'Add' button and then select "MySQL ODBC 3.51 Driver"; install driver from Internet if not present.
3. Give Name as "MySQL-CAWS", IP of server with data, database name, database user [preferably one with read only access] and its password.
4. "Test Data Source" to make sure connection works.

NOTE: the name of the ODBC must be "MySQL-CAWS" otherwise program will not operate properly (this name is hardcoded into the program). If this name requires changing, edit the source object "dbCawsCentral" and change the 'AliasName' as necessary. The program needs to be recompiled in order for this change to take effect.

Usage:

1. Start the *d10analyzer.exe* program.
2. Select the "from/to date/time" and select the types of data to be viewed on graph by clicking on the appropriate check boxes (the more check boxes selected the longer queries will take).
3. Once the hourglass with 'SQL' on bottom of icon disappears, click on 'DB Connect' tab.

There should then be a chart now viewable with data plotted and date/time as x-axis. Using the mouse window a specific section of data to be viewed, drag cursor from left to right, up to down in order to zoom in. To completely zoom out, click and drag cursor from right to left, down to up. If date/time needs to be

changed, make sure to click 'DB Disconnect' button on 'Search' tab otherwise program will not work properly.

Disabled Functions: 'Plot' and 'DBConfig' tabs are disabled and cannot be used.

3.8.2.2 Speed log file conversion

Speed log files are stored in an unreadable format; the *logconverter.exe* program is used to convert the unreadable *.DAT* files into readable *.txt* files.

logconverter.exe

Usage:

1. Start *logconverter.exe*, [Source code/Log Converter/].
2. Navigate using system tree to the location of the log files to be converted.
3. Once log files appear in first list box, click 'Convert Logs' button to output the *.txt* files (the *.txt* files will be output to same directory).

Limitations: Read the 'About' section in 'Help' menu of program. This program has only been tested on Win2k machines.

To further aid in reading and identifying missed speed activations due to problems noted in 3.5.1, an Excel macro is used to import the converted log files and highlight any missed activations or activations that TMC should have activated on.

Speed Conversion.xls

Usage:

1. Open *Speed_Conversion.xls* and 'Enable Macros'.
2. Change the source folder cell to the location of the log files to be converted.

NOTE: Location does not end in '\ ' and source folder can be either one folder with multiple folders underneath it and multiple files in those folders or one folder with multiple files in it.

3. Set 'Include SubFolders:' to true if there are multiple folders underneath source folder or false if you intend to examine one folder with multiple files underneath.
4. Choose a location to save the converted log files (if folder doesn't exist excel will create it).
5. Hit Alt+F8 to run the macro 'Run_Me'. After accepting message box, Excel disappears while macro is running.

NOTE: Processing of log files will take approx. 1min for ever log file so be patient for process to finish. Once finished another message box will appear and excel will become visible again. Files will be found in the save folder.

Excel File Explanation: There will be a sheet for each log processed, after the date there are three tags that might be attached to the sheets name:

- ‘_C’ → Communication Errors [violet]
- ‘_A’ → Situations where there should be activations [yellow]
- ‘_N’ → Situations where coding problems would cause no activation when there should be one [red]

The numbers after the tag indicates the number of those situations that were found. These numbers can be used to identify days where there were major communication problems or speed activations to be examined for further analyzing. There are also FLD errors [light blue] that occur but are not tabulated.

Limitation: The macro was developed to look at folders where each folder contained only log files for a given month. If log files are from more then one month, the macro will not be able to tell and processes the files normally.

3.8.2.3 Weather log file conversion

Weather logs are in a readable format by the human eye. These logs, however, contain a significant amount of information that inhibits a quick visual interpretation. The script *trim_weather_logs.vim* and Excel macro *Weather_Conversion.xls* were developed to analyze the weather logs.

trim_weather_logs.vim

The *trim_weather_logs.vim* script utilizes the program Vim for windows and can be downloaded from www.vim.org. This script was developed and used with *gvim63.exe* for MS-DOS and MS-Windows. Use of this script is required in order to trim the size to the weather log files. The weather log files can contain enough logged error events that the log file cannot be properly imported into Excel.

Setup: Make sure there is a shortcut to gVim on desktop and the location of *trim_weather_logs.vim* script is known.

Usage:

1. Open up folder with weather log files and select all the logs.
2. Change the properties so files are not read-only.
3. Drag and drop files onto the gVim shortcut. This step loads the selected logs into gVim’s buffer.
4. Type in the command `':bufdo! source [script location]'` and hit enter. For example:

`:bufdo! source C:\Weather_Data\Weather_Script\trim_weather_logs.vim`

Processing requires approximately 5-10 minutes depending on the number and the size of the log files. Once cursor returns to upper left hand part of the screen, script is completed. Once the log files have been modified and saved, original log files will remain in the director with a ‘~’ appended to their filenames. Log files should now be smaller then 200k compared to their original size (some files could be

larger than 1M). If any files are larger than 200k, run *trim_weather_logs.vim* script until files are proper size.

Limitations: Script only allows the data that was polled every five minutes to pass. During an activation, data is polled at a faster rate; this script filters out those poles.

Weather_Conversion.xls

Script was developed to make it easier to view log files and identify weather events where there should have been activation.

Usage:

1. Open *Weather_Conversion.xls* and 'Enable Macros'.
2. Change the source folder cell to the location of the log files to be converted.

NOTE: Location does not end in '\ ' and source folder can be either one folder with multiple folders underneath it and multiple files in those folders or one folder with multiple files in it.

3. Set 'Include SubFolders:' to true if there are multiple folders underneath source folder or false if just looking at one folder with multiple files underneath.
4. Choose a location to save the converted log files (if folder doesn't exist Excel will create it).
5. Hit Alt+F8 to run the macro 'Run_Me' (after accepting message box, excel will disappear while macro is running)

NOTE: Processing of log files will take approximately one minute for every log file. Once completed, another message box appears and Excel becomes visible again. Files can be found in the save folder.

Excel File Explanation: There will be a Excel sheet for each log processed. There are four tags that might be attached to the sheets name:

- '_A' → There was a of Master Computer Data Byte Alarm that was not wind or visibility
- '_M' → Communications error 'M' which shows no data was given for that site [yellow]
- '_V' → Visibility activation [red]
- '_W' → Wind activation [green]

The numbers following the tags indicates the number of those situations that were found. These numbers can be used to identify days where there were major communication problems or speed activations.

Limitation: The macro was developed to look at folders where each folder contained only log files for a given month. If log files are from more than one month, the macro will not be able to tell and processes the files normally.

3.8.2.4 Signview Logs

Signview logs are not in a readable format by the human eye but contain a lot of information that is not easily filtered out and looked at easily. The *trim_Signview_logs.vim* script and *Signview_Conversion.xls* Excel macro were developed to analyze the Signview logs.

trim Signview logs.vim

This script utilizes the program Vim for windows and can be downloaded from www.vim.org, this script was developed and used with gvim63.exe for MS-DOS and MS-Windows. The script and Vim are used to handle the NULL characters that are in the log files that cannot be handled properly except through Vim.

Usage:

1. Open up folder with Signview log files and select all the desired logs; change properties so files are not read-only.
2. Drag and drop files onto the gVim shortcut. Doing this loads all selected logs into gVim's buffer.
3. Type in the command `':bufdo! s/[ctrl+q][ctrl+shift+2]/[ctrl+q][ctrl+m]/g'`. This command changes all the NULL characters into CR. The command should look like this- `':bufdo! s/^@/^M/g'` on the screen.

NOTE: the commands in brackets '[']' are actual buttons pressed on keyboard and should not be typed out.

4. Then type in the command `':bufdo source {script location}'` and hit enter. For example:
bufdo! source C:\Signview_Data\Signview_Script\trim_Signview_logs.vim.

After hitting enter, it requires a varying amount of time to complete processing depending on the number of log files selected. Once cursor returns to upper left hand part of the screen, the script has completed. Once all of the log files have been modified and saved, original log files remain in the directory with a '~' appended to the end of their filenames.

Signview Conversion.xls

Usage:

1. Open *Signview_Conversion.xls* and 'Enable Macros'.
 2. Change the source folder cell to the location of the log files to be converted.
- NOTE:** If the location does not end in '\', choose a location to save the converted log files. If selected folder does not exist, Excel will create it.
3. Hit Alt+F8 to run the macro 'Run_Me'. After accepting message box, Excel disappears while the macro is running.

NOTE: Processing requires approximately one minute per log file. Once completed, another message box appears and Excel becomes visible once again. The files are subsequently found in the save folder.

Limitation: This macro was developed to examine one folder and to process one or more log files. This macro, however, does not have the capability of examining sub folders. This macro also orders CMS messages by CMS site, date, and time.

3.8.3 Index to CD Containing Supporting Data and Utilities

A CD is included that contains the supporting data for all analyses in this document.

Raw log files generated by the TMS, Signview and QCMS computers files were acquired from Caltrans D10 TMC. The TMS and Signview log files are generated in a binary format intended to be read only by using the original program. We converted these files to text-readable format using the conversion utilities described in the prior appendix, and listed below. The translated log files listed below, and the conversion utilities, are contained on the Appendix CD. Each log file has been imported into Microsoft Excel for ease of analysis.

```
/Converted TMC Data
  /Signview
    /Signview_Logs.xls
    /Signview_Logs_Seperated_By_Month.xls
  /Speed
    /Apr 2004_Speed.xls
    /Aug 2004_Speed.xls
    /Dec 2004_Speed.xls
    /Feb 2004_Speed.xls
    /Feb 2005_Speed.xls
    /Jan 2004_Speed.xls
    /Jan 2005_Speed.xls
    /Jul 2004_Speed.xls
    /Jun 2004_Speed.xls
    /Mar 2004_Speed.xls
    /Mar 2005_Speed.xls
    /May 2004_Speed.xls
    /Nov 2004_Speed.xls
    /Oct 2004_Speed.xls
    /Sep 2004_Speed.xls
  /Weather
    /Apr 2004_Weather.xls
    /Aug 2004_Weather.xls
    /Dec 2004_Weather.xls
    /Feb 2004_Weather.xls
    /Feb 2005_Weather.xls
    /Jan 2004_Weather.xls
    /Jan 2005_Weather.xls
    /Jul 2004_Weather.xls
    /Jun 2004_Weather.xls
    /Mar 2004_Weather.xls
    /Mar 2005_Weather.xls
    /May 2004_Weather.xls
    /Nov 2004_Weather.xls
    /Oct 2004_Weather.xls
    /Sep 2004_Weather.xls
```

The utilities used to convert the above files:

```
/Conversion Utilities
  /Signview
    /Notes.txt
```



```
    /Signview_Conversion.xls
    /trim_Signview_logs.vim
/Source Code
    /Log Converter    *Contains all source code for logconvert.exe
/Speed
    /logconvert.exe
    /Speed_Conversion.xls
/Weather
    /notes.txt
    /trim_weather_logs.vim
    /Weather_Conversion.xls
```

A program was also developed to help examine the data in the CAWS-evaluation database to rapidly locate fog events and sign responses. It is described in detail in the prior appendix and is included on the CD with source code:

```
/D10-Analyzer
    /d10analyzer.exe    *Also contains all source files
```